

UBH63

UNIVERSAL Power clamps



U	B	H	6	3	N	N	E
1	2	3	4	5	6		

<p>1 Series</p> <p>UB = UNIVERSAL Power clamps fully adjustable opening angle: 0° to 135° Max The opening angle range may vary according to the arm position and style</p>	<p>2 Version</p> <p>H = Pneumatic-standard</p>	<p>3 Size</p> <p>63 = Ø 63 mm</p>
---	--	---

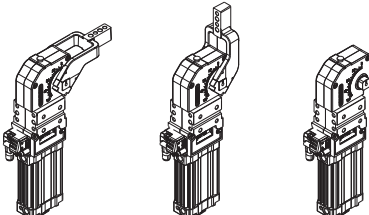
<p>4 Arm position</p> <p>V = 90° O = 180° N = No arm</p> 	<p>5 Arm style</p> <p>C = Central, 15 mm offset D = Right, 15 mm offset S = Left, 15 mm offset E = Central, 45 mm offset F = Right, 45 mm offset L = Left, 45 mm offset N = No arm X = Central, oversized dowel holes Ø 8 H7, 15 mm offset Y = Right, oversized dowel holes Ø 8 H7, 15 mm offset Z = Left, oversized dowel holes Ø 8 H7, 15 mm offset T = Central, oversized dowel holes Ø 8 H7, 45 mm offset U = Right, oversized dowel holes Ø 8 H7, 45 mm offset V = Left, oversized dowel holes Ø 8 H7, 45 mm offset</p>	<p>6 Sensor</p> <p>N = No sensor (with protection plate) E = Electronic sensor with M12 swivel connector D = Pneumatic sensor</p>
--	--	---

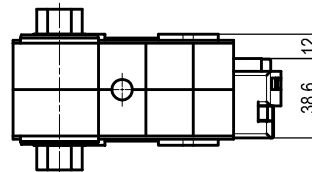
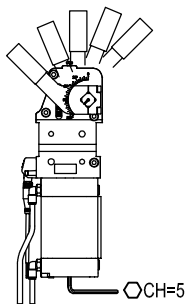
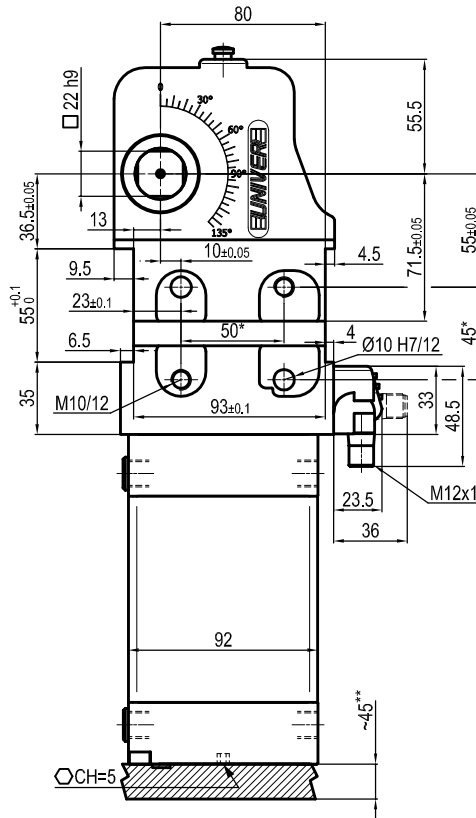
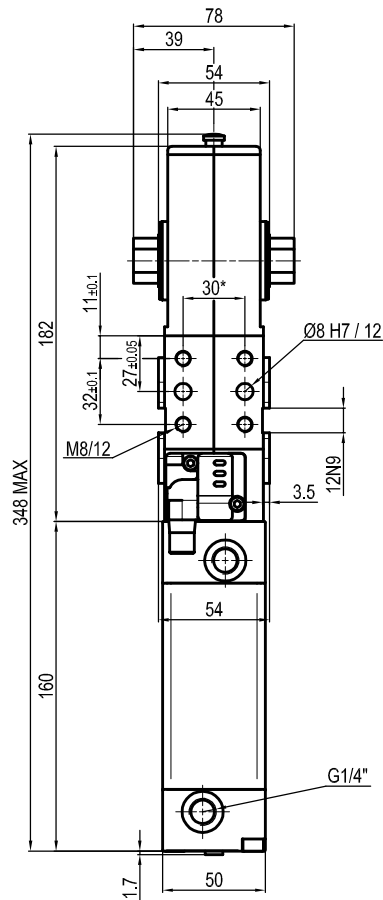

Bore Ø	Holding moment	Clamping moment	Weight (Clamping arm not included)
63 mm	1750 Nm	420 Nm	3.2 Kg

Min./Max. operating pressure: 0,4 / 0,6 MPa

Operating temperature: 5° + 45° C

Opening angle: **adjustable**

Without arm

Electronic sensor with M12 swivel connector that can be orientated at 0° or 90°

Supply voltage: 10÷30 Vdc

IP code: **IP 65**

Pneumatic ports on both sides

* : TOLERANCE BETWEEN DOWELS ± 0.02, TO SCREW HOLES ± 0.1

** : TOLERANCE AT 80 mm FROM PIVOT POINT

Subject to technical modifications without notice

UNIVERSAL Pneumatic clamp

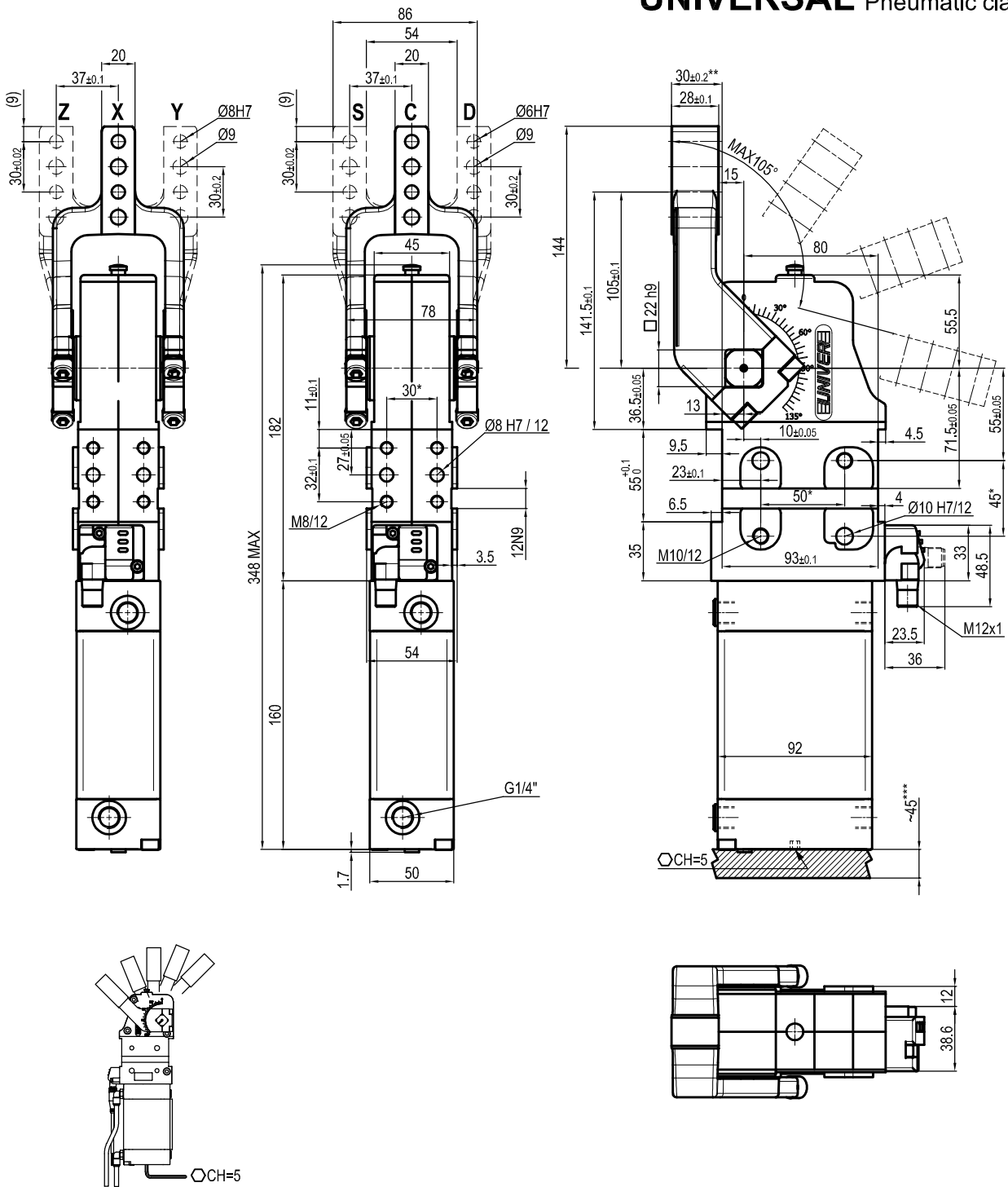

Bore Ø	Holding moment	Clamping moment	Weight (Clamping arm not included)
63 mm	1750 Nm	420 Nm	3.2 Kg

Min./Max. operating pressure: 0,4 / 0,6 MPa
 Operating temperature: 5° + 45° C
 Opening angle: adjustable from 0° to 105°
 Horizontal arm mount position
 Electronic sensor with M12 swivel connector that can be orientated at 0° or 90°
 Supply voltage: 10÷30 Vdc
 IP code: IP 65
 Pneumatic ports on both sides

* : TOLERANCE BETWEEN DOWELS ± 0.02, TO SCREW HOLES ± 0.1
 ** : TOLERANCE AT 80 mm FROM PIVOT POINT
 *** : AREA TO ACCESS ANGLE ADJUSTMENT

Subject to technical modifications without notice

UNIVERSAL Pneumatic clamp at 45 mm from pivot point

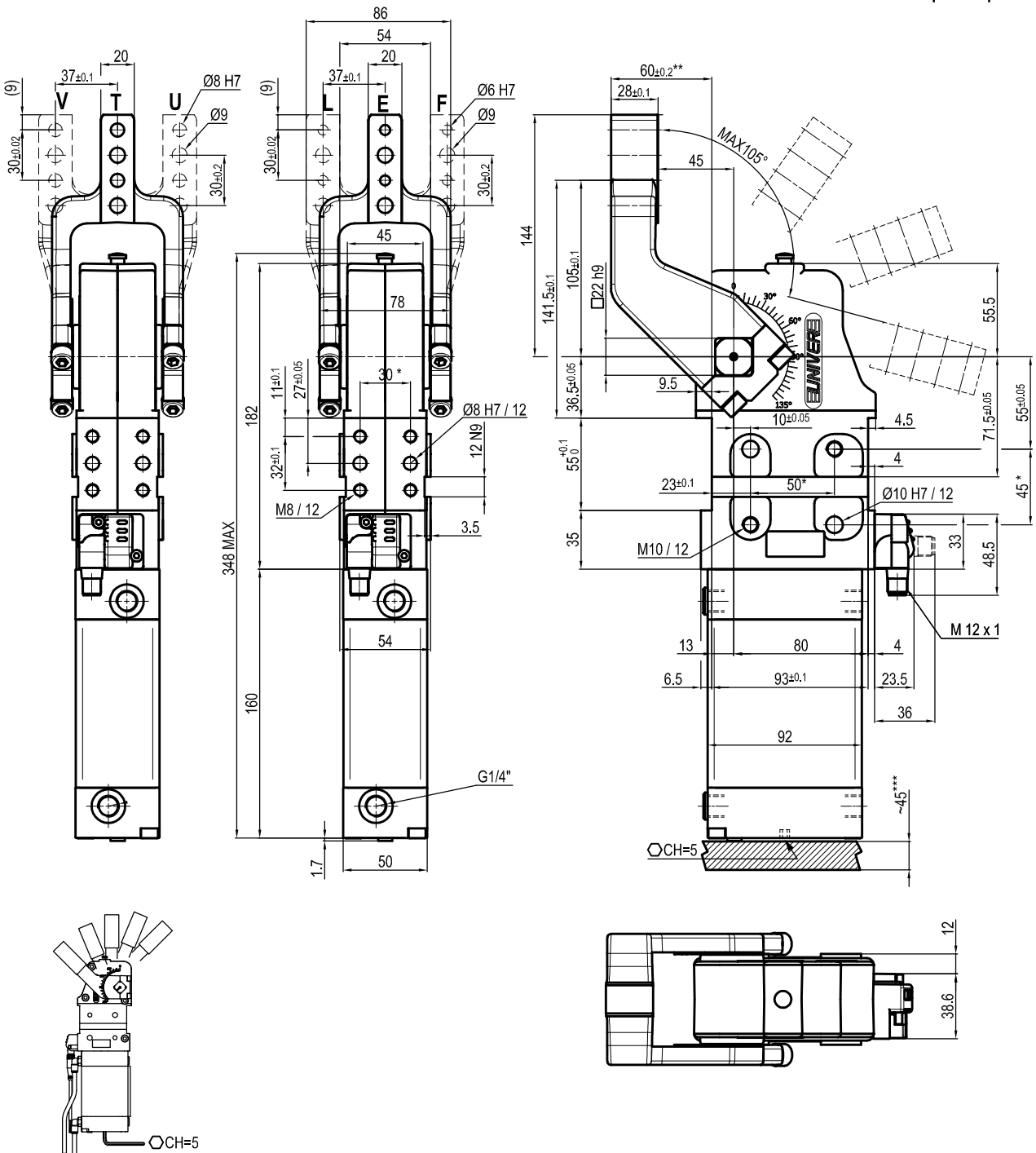

Bore Ø	Holding moment	Clamping moment	Weight (Clamping arm not included)
63 mm	1750 Nm	420 Nm	3.2 Kg

Min./Max. operating pressure: 0,4 / 0,6 MPa
 Operating temperature: 5° + 45° C
 Opening angle: adjustable from 0° to 105°
 Horizontal arm mount position
 Electronic sensor with M12 swivel connector that can be orientated at 0° or 90°
 Supply voltage: 10÷30 Vdc
 IP code: IP 65
 Pneumatic ports on both sides

* : TOLERANCE BETWEEN DOWELS ± 0.02, TO SCREW HOLES ± 0.1
 ** : TOLERANCE AT 80 mm FROM PIVOT POINT
 *** : AREA TO ACCESS ANGLE ADJUSTMENT

Subject to technical modifications without notice

UNIVERSAL Pneumatic clamp

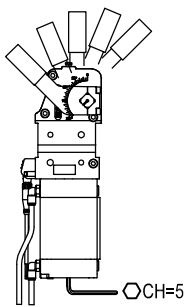
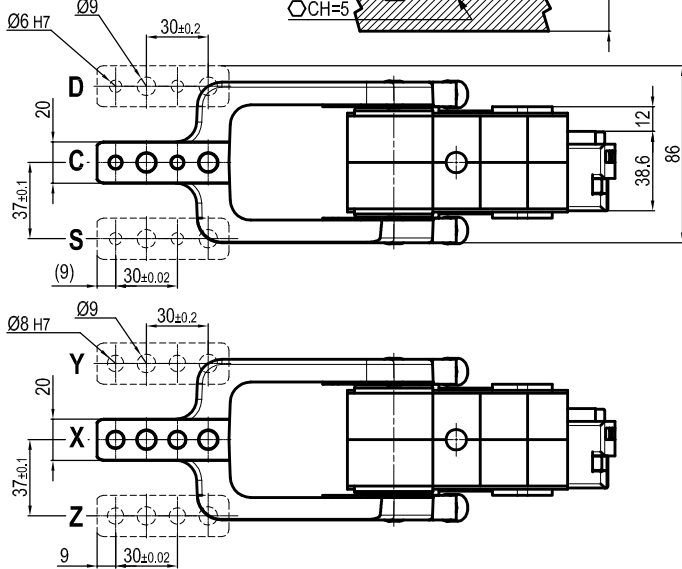
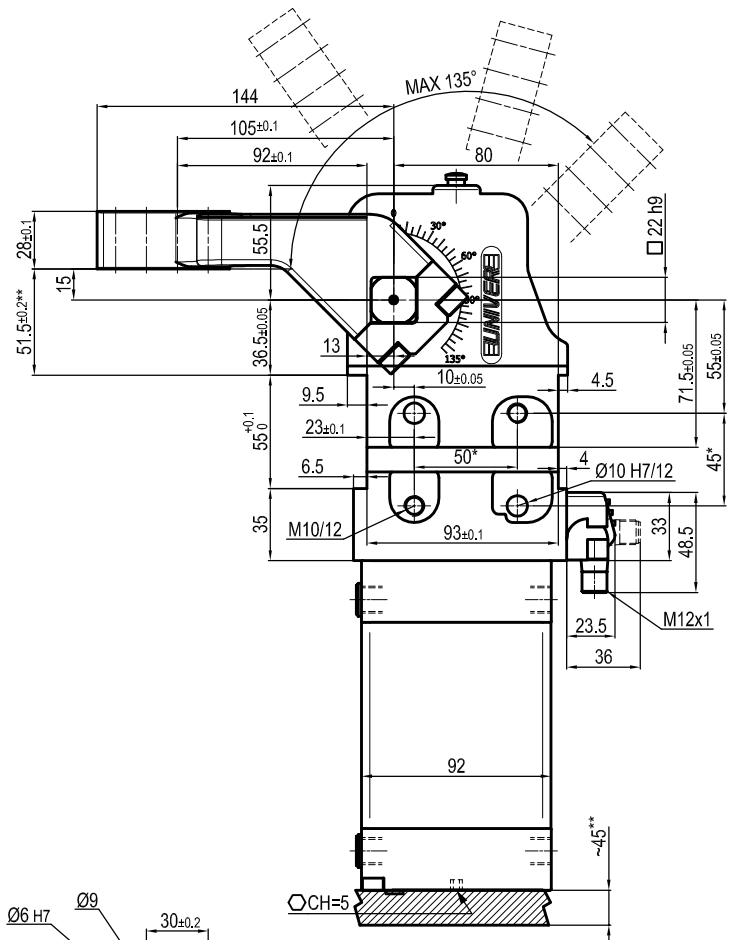
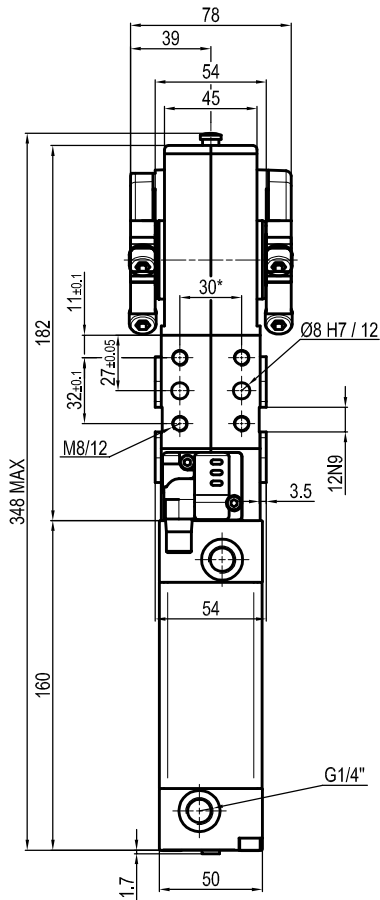

Bore Ø	Holding moment	Clamping moment	Weight (Clamping arm not included)
63 mm	1750 Nm	420 Nm	3.2 Kg

Min./Max. operating pressure: 0,4 / 0,6 MPa
 Operating temperature: 5° + 45° C
 Opening angle: adjustable from 0° to 135°
 Vertical arm mount position
 Electronic sensor with M12 swivel connector that can be orientated at 0° or 90°
 Supply voltage: 10÷30 Vdc
 IP code: IP 65
 Pneumatic ports on both sides

* : TOLERANCE BETWEEN DOWELS ± 0.02, TO SCREW HOLES ± 0.1
 ** : TOLERANCE AT 80 mm FROM PIVOT POINT
 *** : AREA TO ACCESS ANGLE ADJUSTMENT

Subject to technical modifications without notice

UNIVERSAL Pneumatic clamp at 45 mm from pivot point

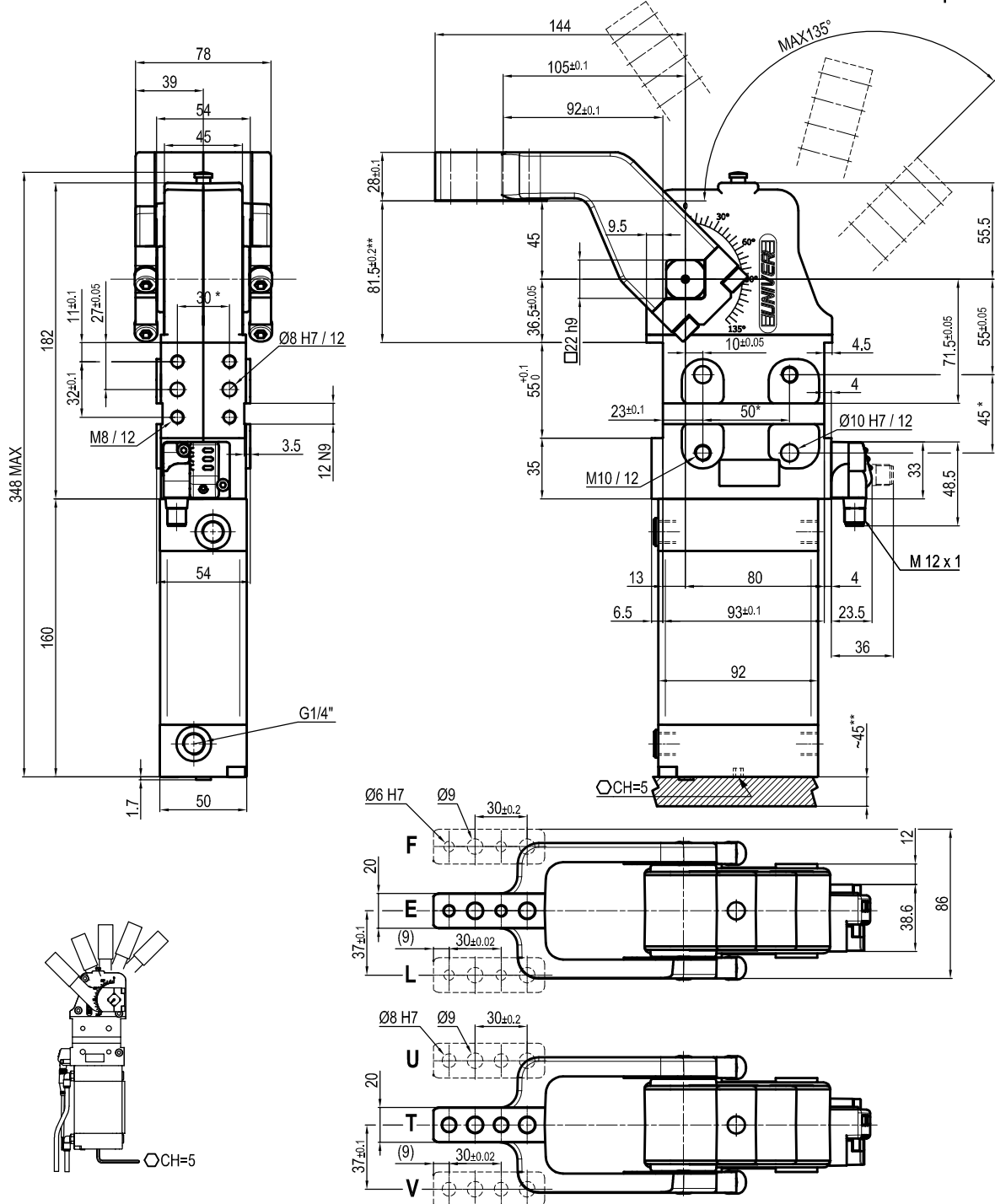

Bore Ø	Holding moment	Clamping moment	Weight (Clamping arm not included)
63 mm	1750 Nm	420 Nm	3.2 Kg

Min./Max. operating pressure: **0,4 / 0,6 MPa**

Operating temperature: **5° + 45° C**

Opening angle: **adjustable from 0° to 135°**

Vertical arm mount position

Electronic sensor with M12 swivel connector that can be orientated at 0° or 90°

Supply voltage: 10÷30 Vdc

IP code: **IP 65**

Pneumatic ports on both sides

* : TOLERANCE BETWEEN DOWELS ± 0.02, TO SCREW HOLES ± 0.1

** : TOLERANCE AT 80 mm FROM PIVOT POINT

*** : AREA TO ACCES ANGLE ADJUSTMENT

Subject to technical modifications without notice