

UBM50

UNIVERSAL Power clamps



U	B	M	5	0	N	N	E
1	2	3	4	5	6		

1 Series	2 Version	3 Size
UB = UNIVERSAL Power clamps fully adjustable opening angle: 0° to 135° Max The opening angle range may vary according to the arm position and style	M = Pneumatic with manual lever	50 = Ø 50 mm

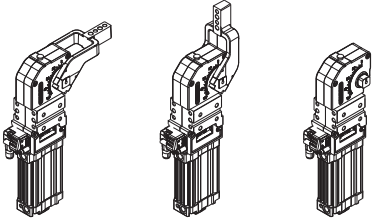
4 Arm position	5 Arm style	6 Sensor
V = 90° O = 180° N = No arm 	C = Central, 15 mm offset (standard) D = Right, 15 mm offset (standard) S = Left, 15 mm offset (standard) E = Central, 45mm offset F = Right, 45mm offset L = Left, 45mm offset N = No arm X = Central, oversized dowel holes Ø 8 H7, 15 mm offset Y = Right, oversized dowel holes Ø 8 H7, 15 mm offset Z = Left, oversized dowel holes Ø 8 H7, 15 mm offset T = Central, oversized dowel holes Ø 8 H7, 45 mm offset U = Right, oversized dowel holes Ø 8 H7, 45 mm offset V = Left, oversized dowel holes Ø 8 H7, 45 mm offset	N = No sensor (with protection plate) E = Electronic sensor with M12 swivel connector D = Pneumatic sensor

UNIVERSAL Pneumatic clamp with manual lever

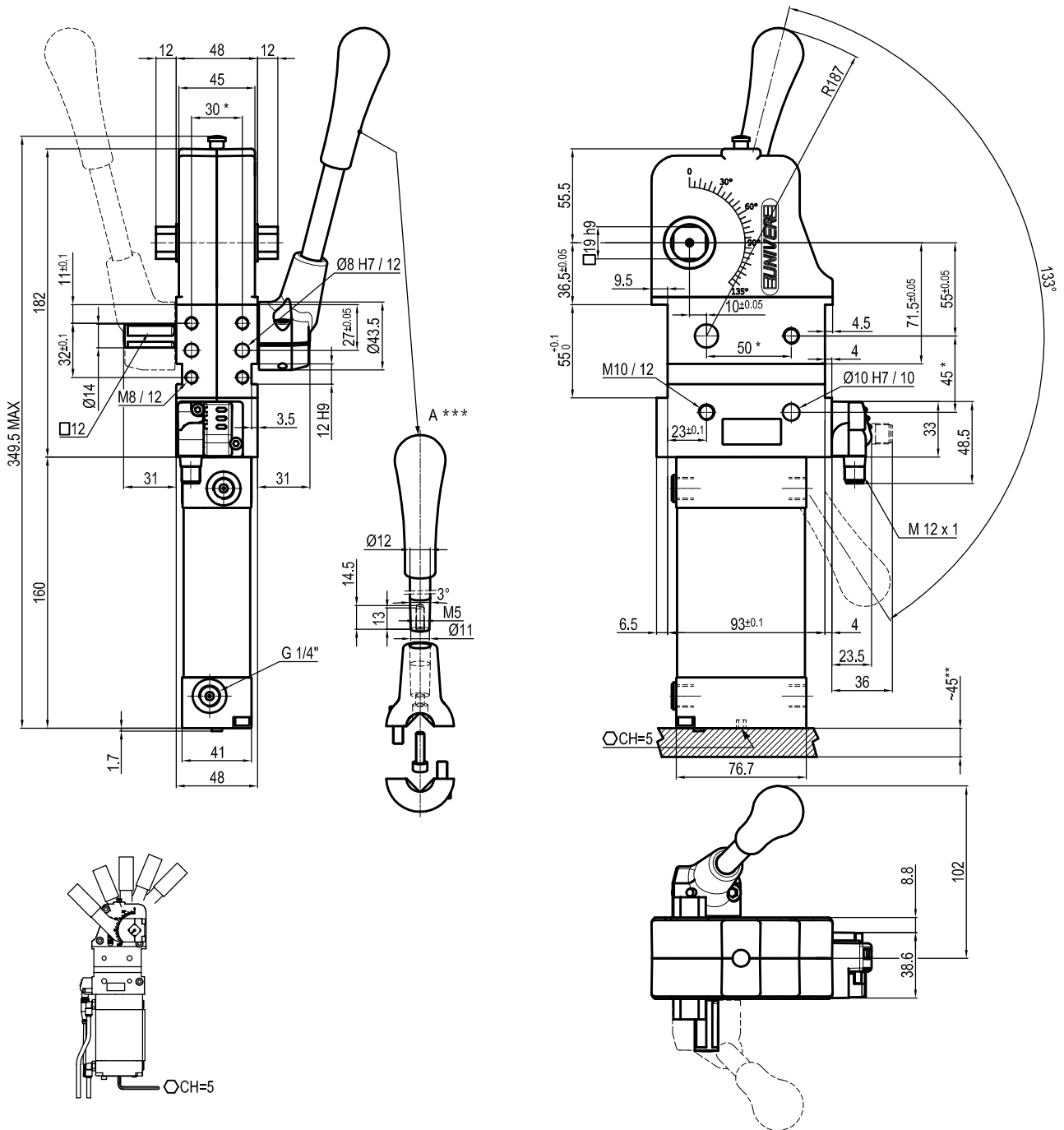

Bore Ø	Holding moment	Clamping moment	Weight (Clamping arm not included)
50 mm	1250 Nm	280 Nm	3.5 Kg

Min./Max. operating pressure: **0,4 / 0,6 MPa**

Operating temperature: **5° + 45° C**

Opening angle: **adjustable**

Without arm

With manual lever

Electronic sensor with M12 swivel connector that can be orientated at 0° or 90°

Supply voltage: 10+30 Vdc

IP code: **IP 65**

Pneumatic ports on both sides

* : TOLERANCE BETWEEN DOWELS ± 0.02, TO SCREW HOLES ± 0.1

** : AREA TO ACCESS ANGLE ADJUSTMENT

*** : DIMENSIONS TO BE RESPECTED IN CASE OTHER MANUAL LEVERS ARE USED

Subject to technical modifications without notice

UNIVERSAL Pneumatic clamp with manual lever

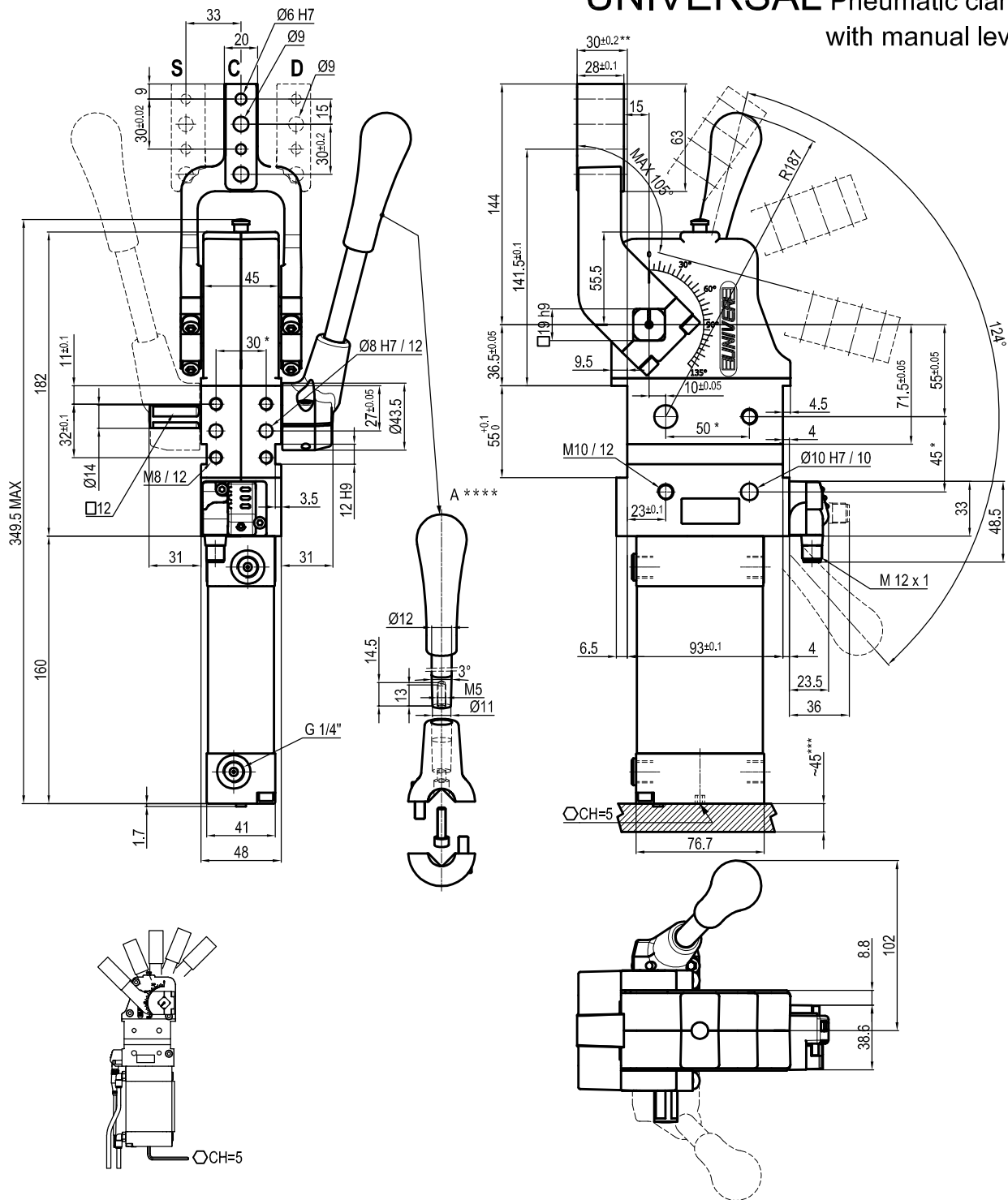

Bore Ø	Holding moment	Clamping moment	Weight (Clamping arm not included)
50 mm	1250 Nm	280 Nm	3.5 Kg

Min./Max. operating pressure: **0,4 / 0,6 MPa**

Operating temperature: **5° + 45° C**

Opening angle: **adjustable from 0° to 105°**

Horizontal arm mount position

With manual lever

Electronic sensor with M12 swivel connector that can be orientated at 0° or 90°

Supply voltage: 10+30 Vdc

IP code: **IP 65**

Pneumatic ports on both sides

* : TOLERANCE BETWEEN DOWELS ± 0.02, TO SCREW HOLES ± 0.1

** : TOLERANCE AT 80 mm FROM PIVOT POINT

*** : AREA TO ACCES ANGLE ADJUSTMENT

**** : DIMENSIONS TO BE RESPECTED IN CASE OTHER MANUAL LEVERS ARE USED

Subject to technical modifications without notice

UNIVERSAL Pneumatic power clamp with manual lever arm at 45 mm from pivot point (arm style E-L-F)

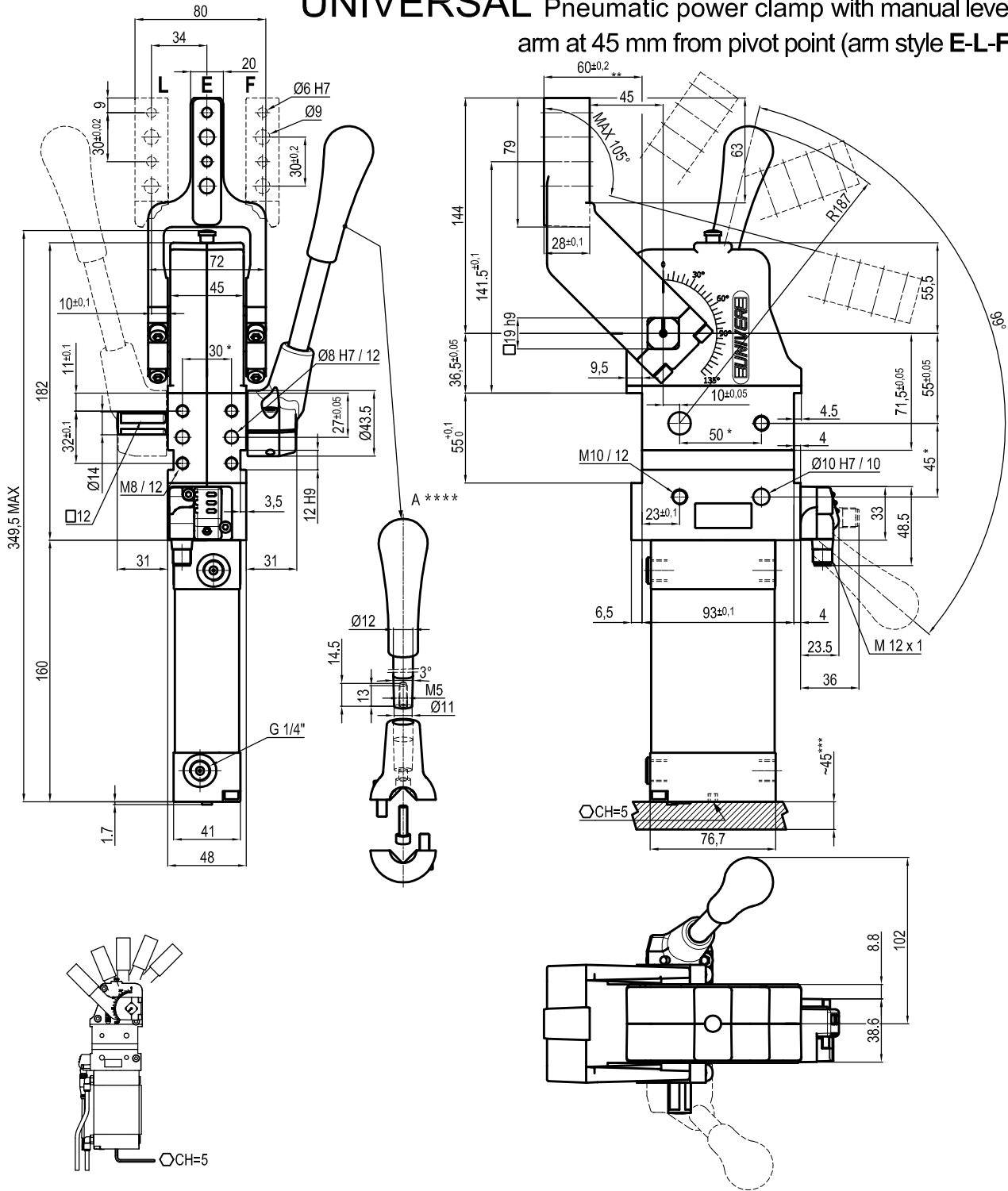

Bore Ø	Holding moment	Clamping moment	Weight (Clamping arm not included)
50 mm	1250 Nm	280 Nm	3.5 Kg

Min./Max. operating pressure: **0,4 / 0,6 MPa**

Operating temperature: **5° + 45° C**

Opening angle: **adjustable from 0° to 105°**

Horizontal arm mount position

With manual lever

Electronic sensor with M12 swivel connector that can be orientated at 0° or 90°

Supply voltage: 10+30 Vdc

IP code: **IP 65**

Pneumatic ports on both sides

* : TOLERANCE BETWEEN DOWELS ± 0.02, TO SCREW HOLES ± 0.1

** : TOLERANCE AT 80 mm FROM PIVOT POINT

*** : AREA TO ACCES ANGLE ADJUSTMENT

**** : DIMENSIONS TO BE RESPECTED IN CASE OTHER MANUAL LEVERS ARE USED

Subject to technical modifications without notice

UNIVERSAL Pneumatic power clamp with manual lever arm at 45 mm from pivot point (arm style V-T-U)

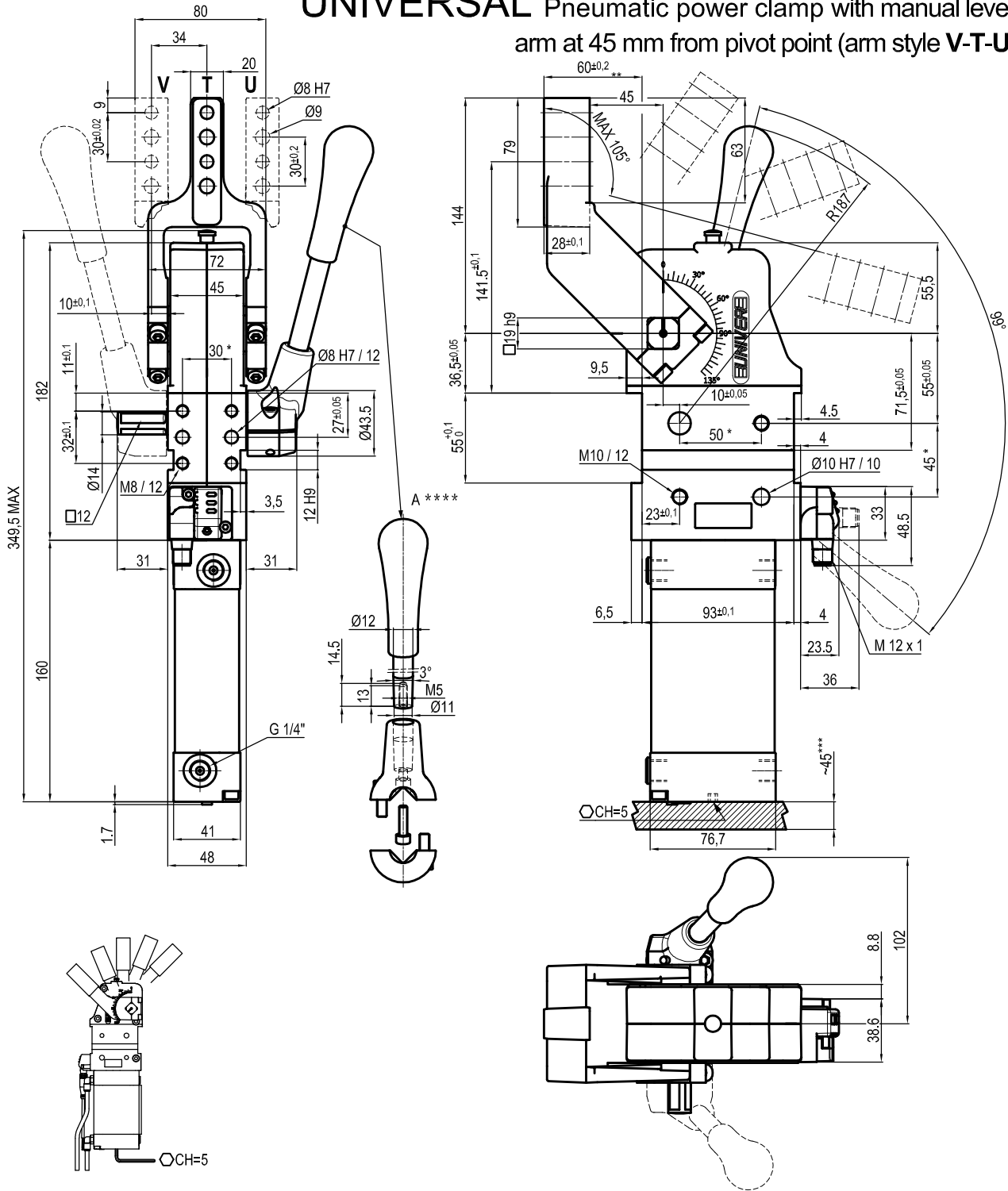

Bore Ø	Holding moment	Clamping moment	Weight (Clamping arm not included)
50 mm	1250 Nm	280 Nm	3.5 Kg

Min./Max. operating pressure: **0,4 / 0,6 MPa**

Operating temperature: **5° + 45° C**

Opening angle: **adjustable from 0° to 105°**

Horizontal arm mount position

With manual lever

Electronic sensor with M12 swivel connector that can be orientated at 0° or 90°

Supply voltage: 10+30 Vdc

IP code: **IP 65**

Pneumatic ports on both sides

* : TOLERANCE BETWEEN DOWELS ± 0.02, TO SCREW HOLES ± 0.1

** : TOLERANCE AT 80 mm FROM PIVOT POINT

*** : AREA TO ACCES ANGLE ADJUSTMENT

**** : DIMENSIONS TO BE RESPECTED IN CASE OTHER MANUAL LEVERS ARE USED

Subject to technical modifications without notice

UNIVERSAL Pneumatic power clamp with manual lever (arm style X-Y-Z)

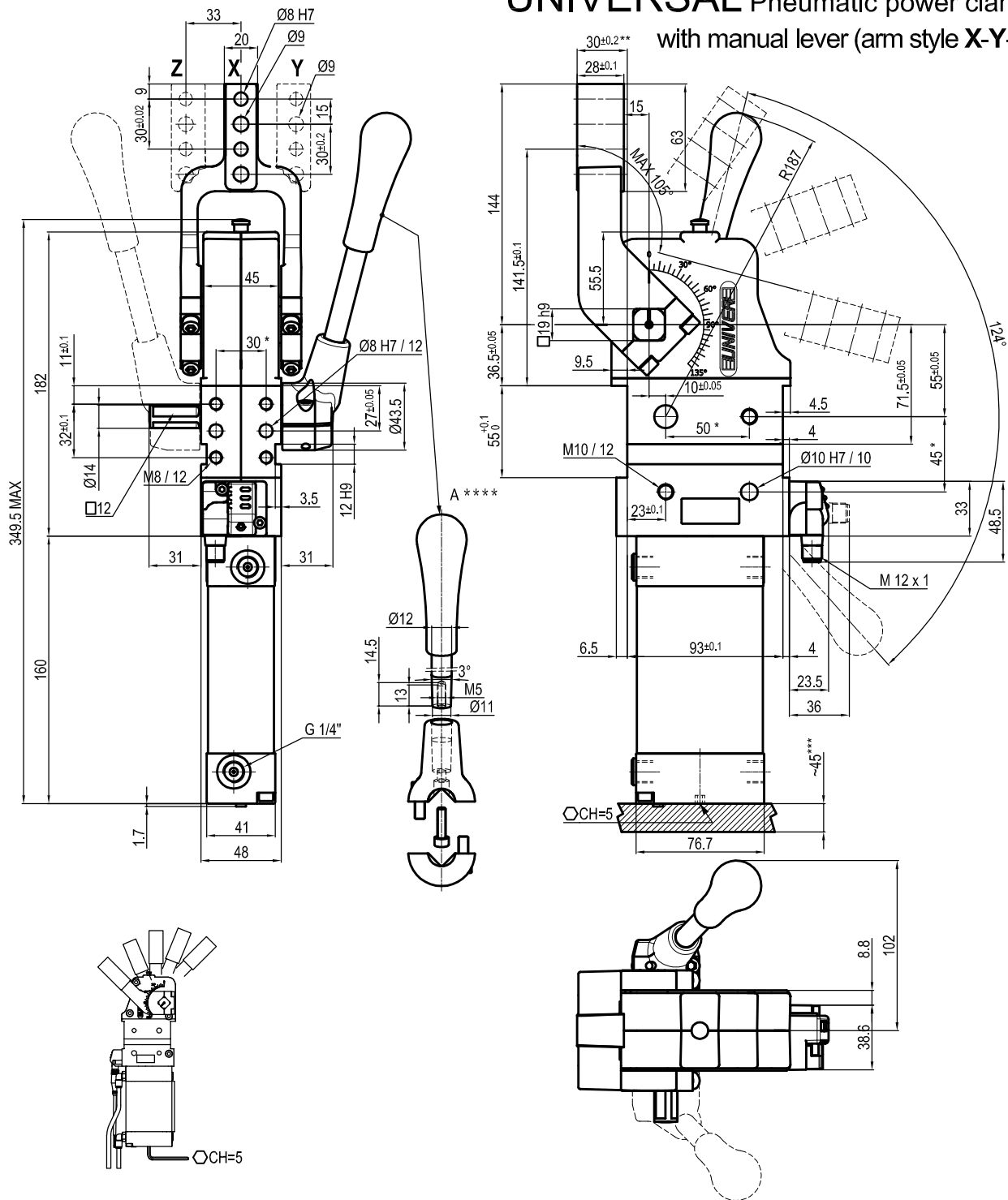

Bore Ø	Holding moment	Clamping moment	Weight (Clamping arm not included)
50 mm	1250 Nm	280 Nm	3.5 Kg

Min./Max. operating pressure: **0,4 / 0,6 MPa**

Operating temperature: **5° + 45° C**

Opening angle: **adjustable from 0° to 105°**

Horizontal arm mount position

With manual lever

Electronic sensor with M12 swivel connector that can be orientated at 0° or 90°

Supply voltage: 10+30 Vdc

IP code: **IP 65**

Pneumatic ports on both sides

* : TOLERANCE BETWEEN DOWELS ± 0.02, TO SCREW HOLES ± 0.1

** : TOLERANCE AT 80 mm FROM PIVOT POINT

*** : AREA TO ACCES ANGLE ADJUSTMENT

**** : DIMENSIONS TO BE RESPECTED IN CASE OTHER MANUAL LEVERS ARE USED

Subject to technical modifications without notice

UNIVERSAL Pneumatic clamp with manual lever

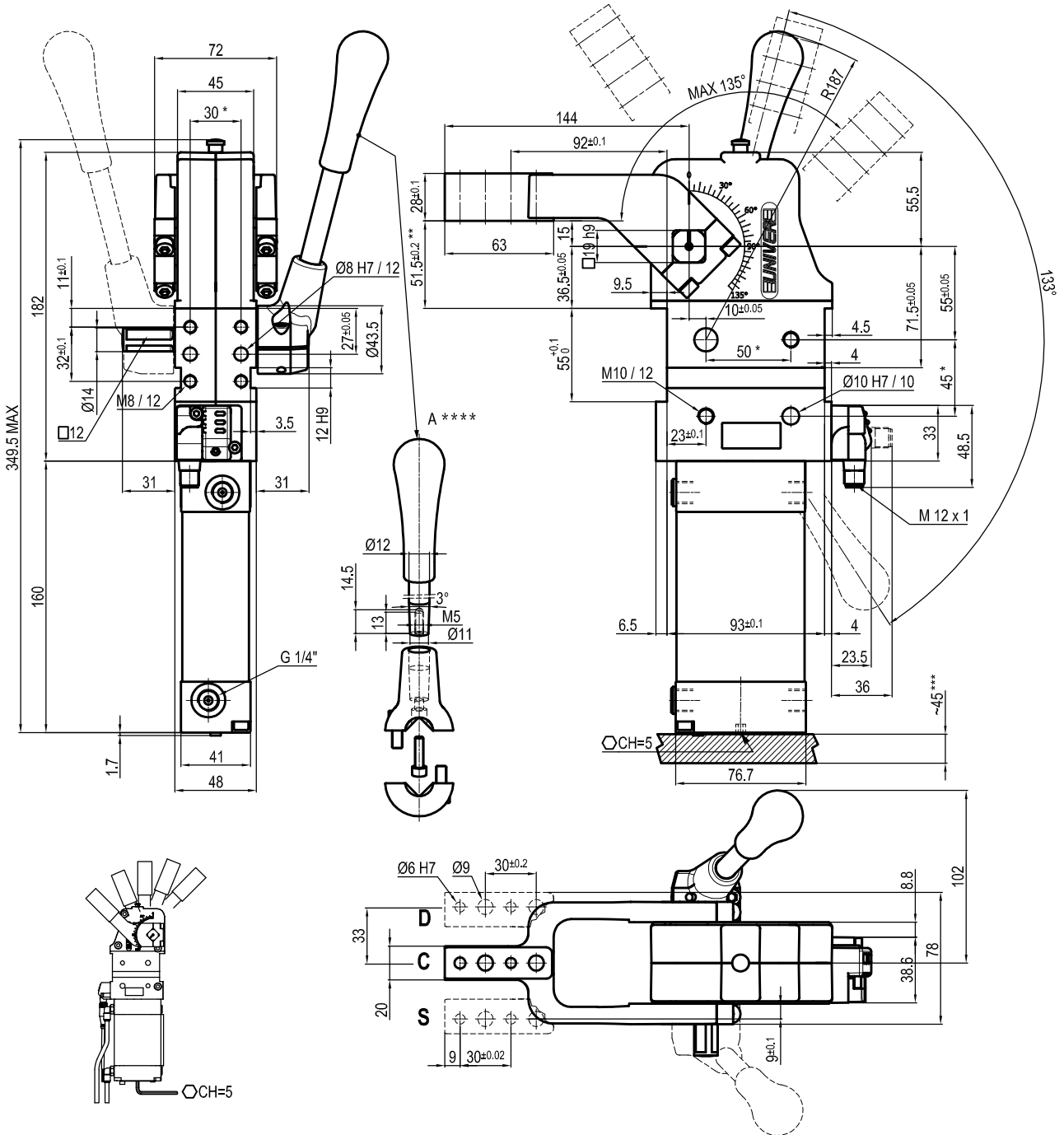

Bore Ø	Holding moment	Clamping moment	Weight (Clamping arm not included)
50 mm	1250 Nm	280 Nm	3.5 Kg

Min./Max. operating pressure: **0,4 / 0,6 MPa**
 Operating temperature: **5° + 45° C**
 Opening angle: **adjustable from 0° to 135°**
 Vertical arm mount position
 With manual lever
 Electronic sensor with M12 swivel connector that can be orientated at 0° or 90°
 Supply voltage: 10+30 Vdc
 IP code: **IP 65**
 Pneumatic ports on both sides

* : TOLERANCE BETWEEN DOWELS ± 0.02, TO SCREW HOLES ± 0.1
 ** : TOLERANCE AT 80 mm FROM PIVOT POINT
 *** : AREA TO ACCES ANGLE ADJUSTMENT
 **** : DIMENSIONS TO BE RESPECTED IN CASE OTHER MANUAL LEVERS ARE USED

Subject to technical modifications without notice

UNIVERSAL Pneumatic power clamp with manual lever arm at 45 mm from pivot point (arm style E-L-F)

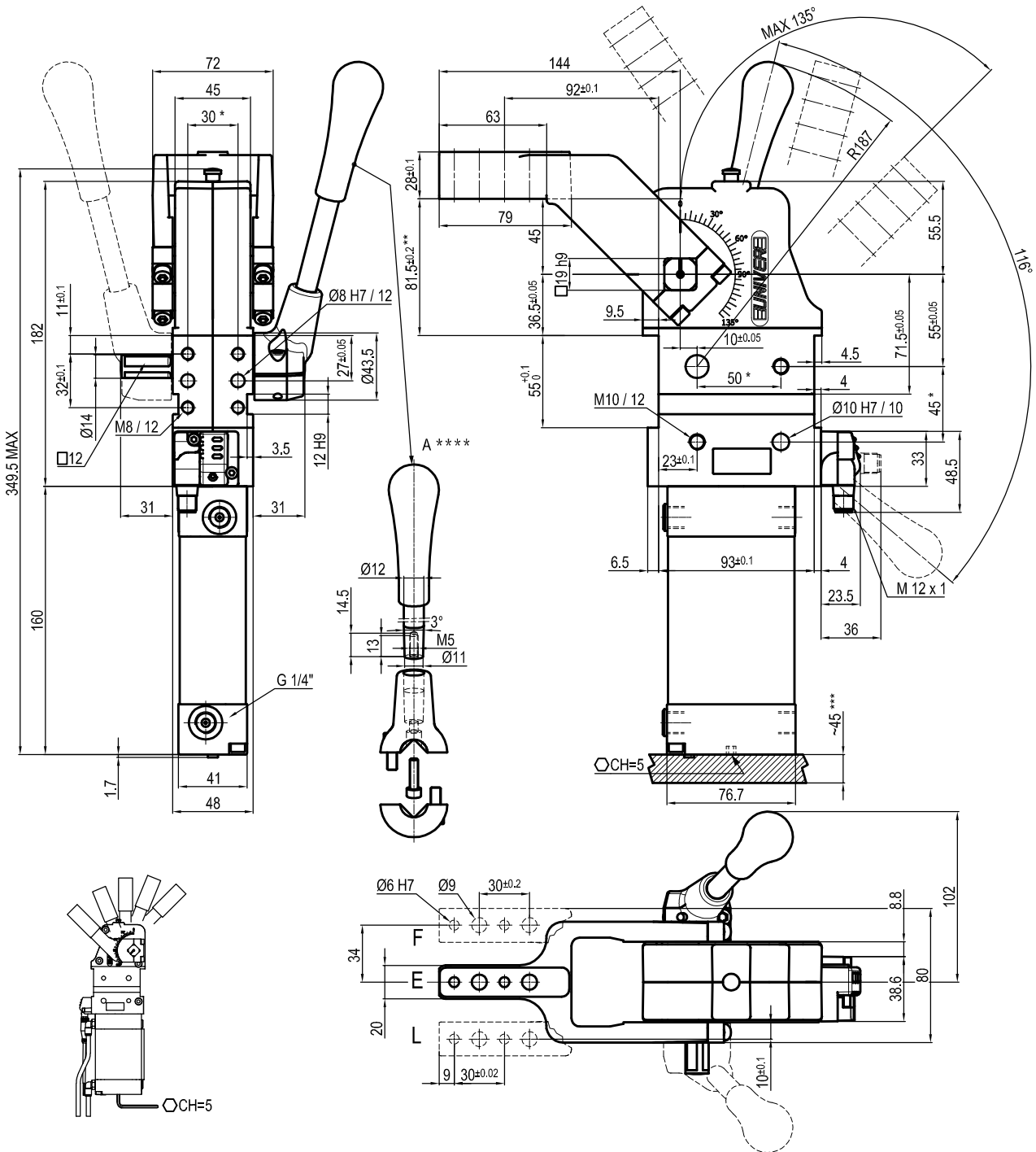

Bore Ø	Holding moment	Clamping moment	Weight (Clamping arm not included)
50 mm	1250 Nm	280 Nm	3.5 Kg

Min./Max. operating pressure: **0,4 / 0,6 MPa**

Operating temperature: **5° + 45° C**

Opening angle: **adjustable from 0° to 135°**

Vertical arm mount position

With manual lever

Electronic sensor with M12 swivel connector that can be orientated at 0° or 90°

Supply voltage: 10+30 Vdc

IP code: **IP 65**

Pneumatic ports on both sides

* : TOLERANCE BETWEEN DOWELS ± 0.02, TO SCREW HOLES ± 0.1

** : TOLERANCE AT 80 mm FROM PIVOT POINT

*** : AREA TO ACCESS ANGLE ADJUSTMENT

**** : DIMENSIONS TO BE RESPECTED IN CASE OTHER MANUAL LEVERS ARE USED

Subject to technical modifications without notice

UNIVERSAL Pneumatic power clamp with manual lever arm at 45 mm from pivot point (arm style V-T-U)

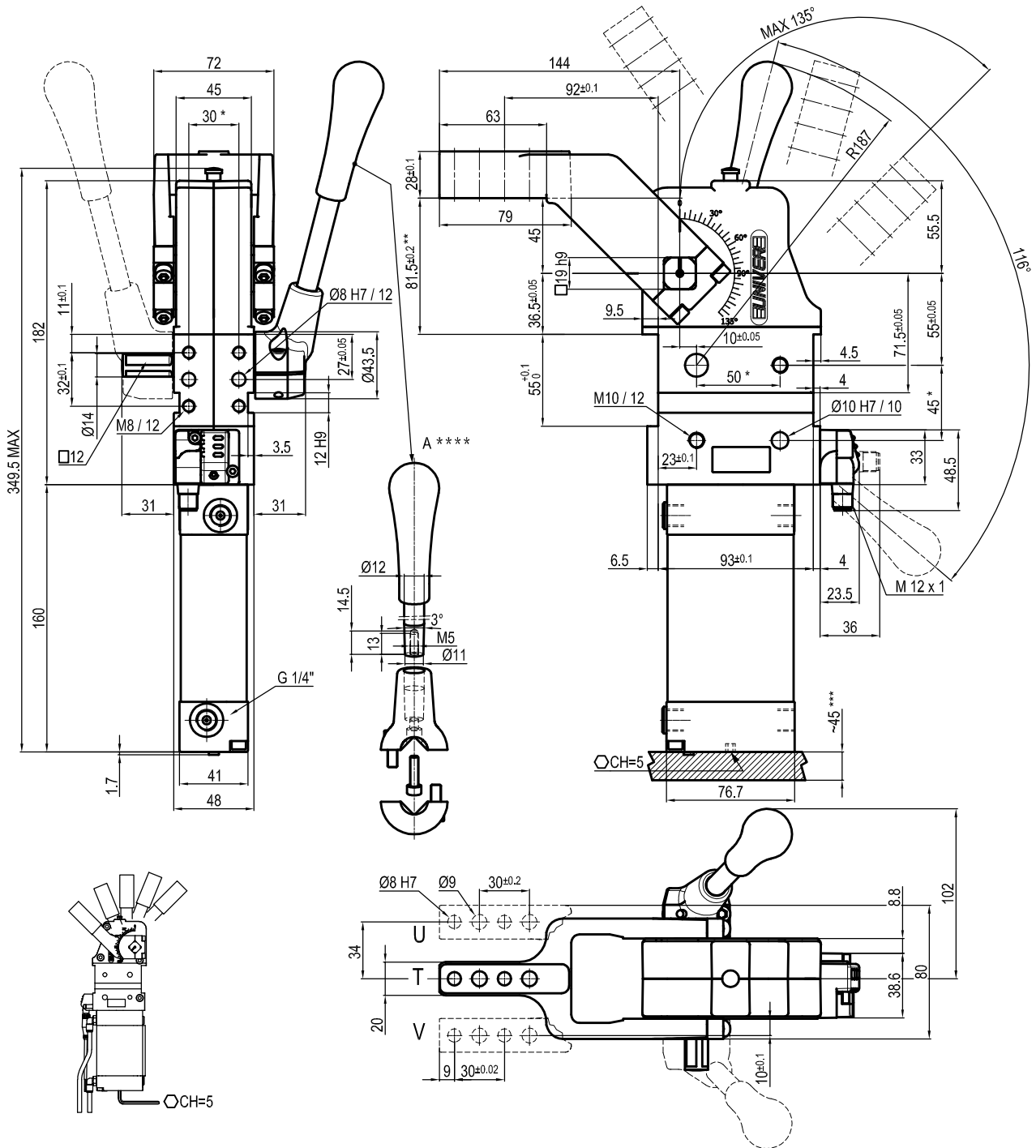

Bore Ø	Holding moment	Clamping moment	Weight (Clamping arm not included)
50 mm	1250 Nm	280 Nm	3.5 Kg

Min./Max. operating pressure: **0,4 / 0,6 MPa**

Operating temperature: **5° + 45° C**

Opening angle: **adjustable from 0° to 135°**

Vertical arm mount position

With manual lever

Electronic sensor with M12 swivel connector that can be orientated at 0° or 90°

Supply voltage: 10+30 Vdc

IP code: **IP 65**

Pneumatic ports on both sides

* : TOLERANCE BETWEEN DOWELS ± 0.02, TO SCREW HOLES ± 0.1

** : TOLERANCE AT 80 mm FROM PIVOT POINT

*** : AREA TO ACCESS ANGLE ADJUSTMENT

**** : DIMENSIONS TO BE RESPECTED IN CASE OTHER MANUAL LEVERS ARE USED

Subject to technical modifications without notice

UNIVERSAL Pneumatic power clamp with manual lever (arm style X-Y-Z)

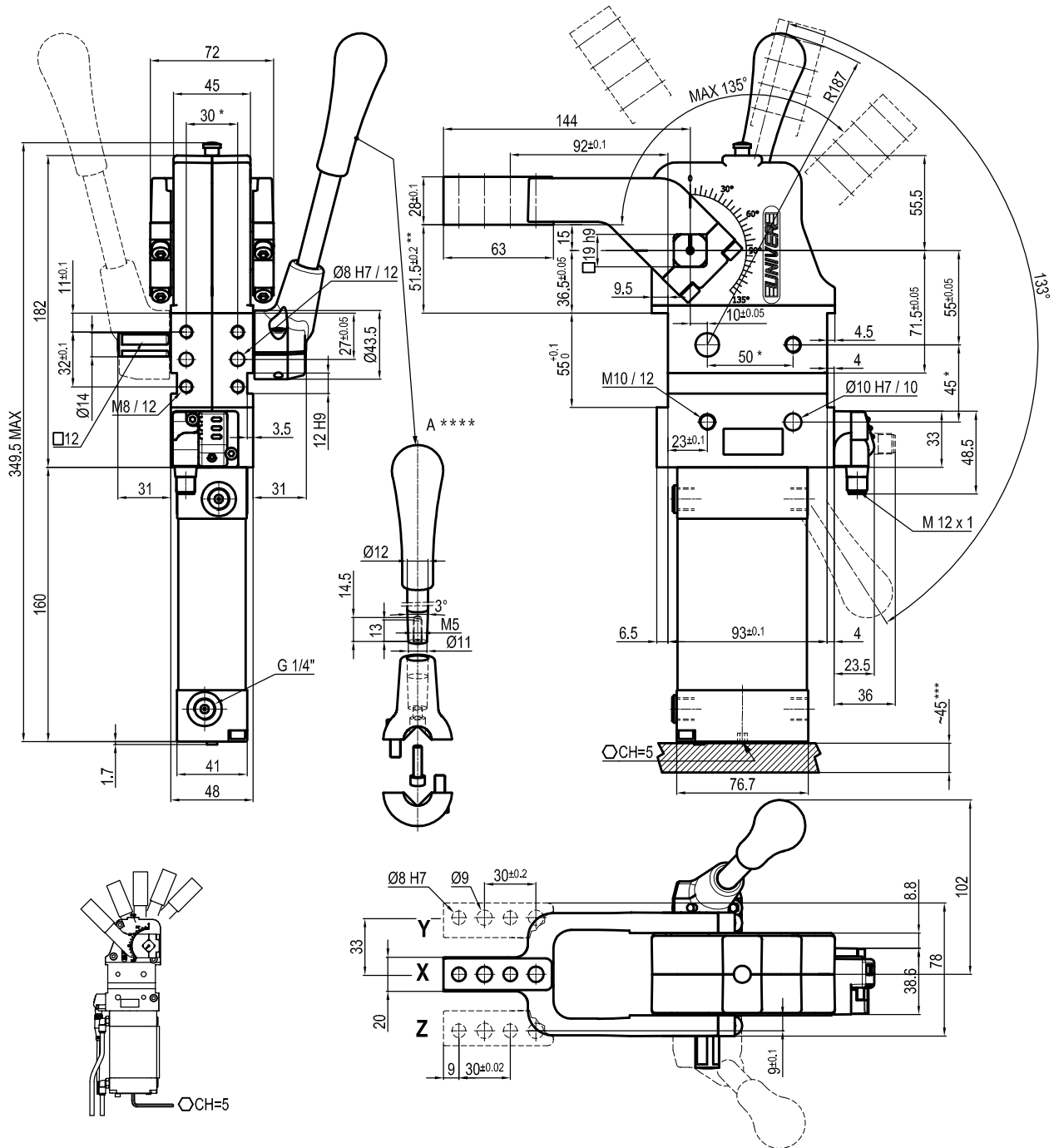

Bore Ø	Holding moment	Clamping moment	Weight (Clamping arm not included)
50 mm	1250 Nm	280 Nm	3.5 Kg

Min./Max. operating pressure: **0,4 / 0,6 MPa**

Operating temperature: **5° + 45° C**

Opening angle: **adjustable from 0° to 135°**

Vertical arm mount position

With manual lever

Electronic sensor with M12 swivel connector that can be orientated at 0° or 90°

Supply voltage: 10+30 Vdc

IP code: **IP 65**

Pneumatic ports on both sides

* : TOLERANCE BETWEEN DOWELS ± 0.02, TO SCREW HOLES ± 0.1

** : TOLERANCE AT 80 mm FROM PIVOT POINT

*** : AREA TO ACCESS ANGLE ADJUSTMENT

**** : DIMENSIONS TO BE RESPECTED IN CASE OTHER MANUAL LEVERS ARE USED

Subject to technical modifications without notice