

UBQ40

UNIVERSAL Power clamps



U	B	Q	4	0	N	N	E
1	2	3	4	5	6		

1 Series UB = UNIVERSAL Power clamps fully adjustable opening angle: 0° to 135° Max The opening angle range may vary according to the arm position and style	2 Version Q = Pneumatic with manual lever	3 Size 40 = Ø 40 mm
--	--	--------------------------------------

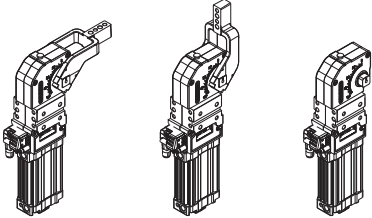
4 Arm position V = 90° O = 180° N = No arm 	5 Arm style C = Central, 15 mm offset (standard) D = Right, 15 mm offset (standard) S = Left, 15 mm offset (standard) E = Central, 45mm offset F = Right, 45mm offset L = Left, 45mm offset N = No arm X = Central, oversized dowel holes Ø 8 H7, 15 mm offset Y = Right, oversized dowel holes Ø 8 H7, 15 mm offset Z = Left, oversized dowel holes Ø 8 H7, 15 mm offset	6 Sensor N = No sensor (with protection plate) E = Electronic sensor with M12 swivel connector D = Pneumatic sensor
--	--	--

UNIVERSAL Pneumatic clamp with manual lever

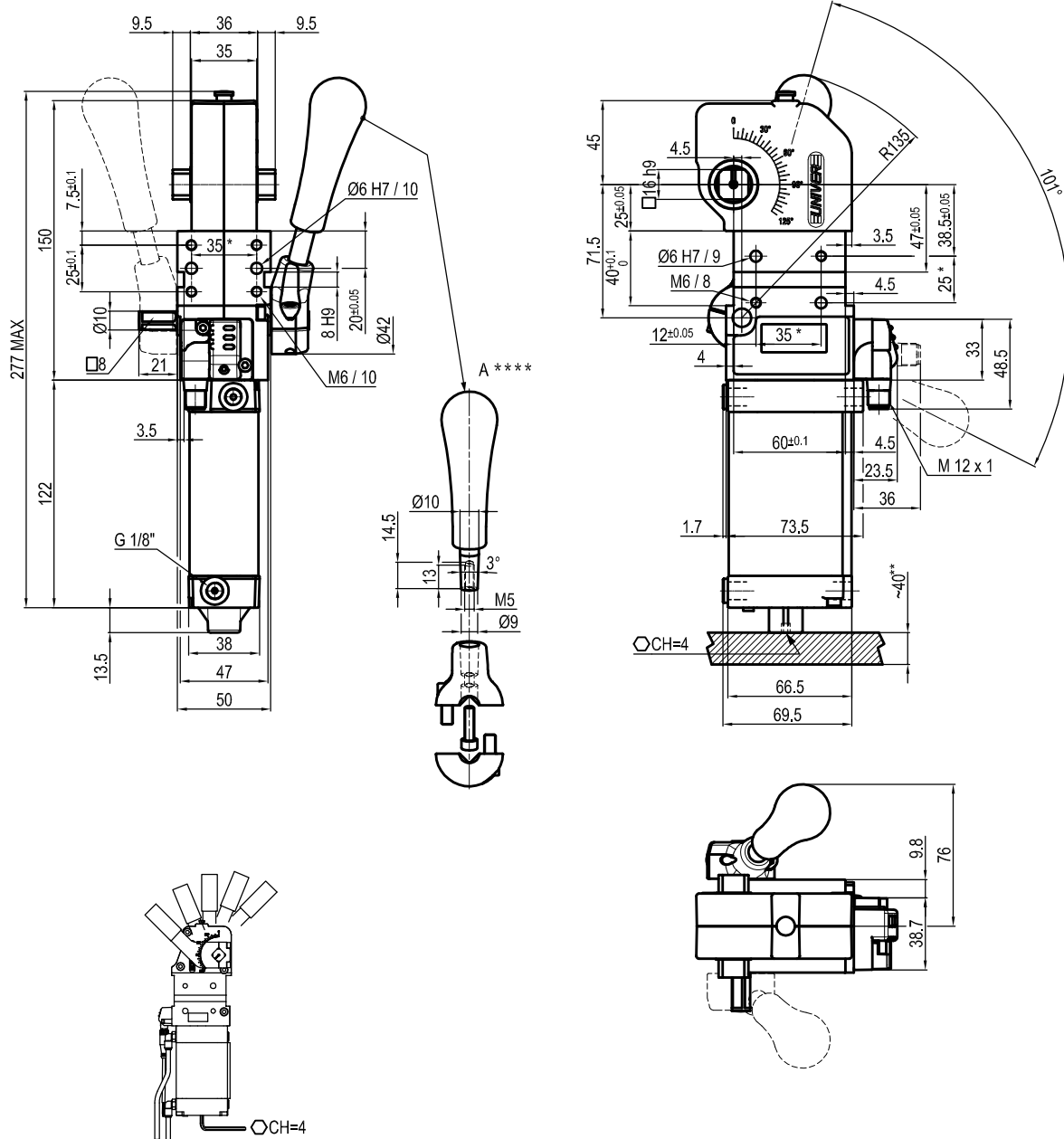

Bore Ø	Holding moment	Clamping moment	Weight (Clamping arm not included)
40 mm	600 Nm	170 Nm	1.8 Kg

Min./Max. operating pressure: **0,4 / 0,6 MPa**

Operating temperature: **5° + 45° C**

Opening angle: **adjustable**

Without arm

With manual lever

Electronic sensor with M12 swivel connector that can be orientated at 0° or 90°

Supply voltage: 10+30 Vdc

IP code: **IP 65**

Pneumatic ports on both sides

* : TOLERANCE BETWEEN DOWELS ± 0.02, TO SCREW HOLES ± 0.1

** : AREA TO ACCESS ANGLE ADJUSTMENT

*** : DIMENSIONS TO BE RESPECTED IN CASE OTHER MANUAL LEVERS ARE USED

**** : DIMENSIONS TO BE RESPECTED IN CASE OTHER MANUAL LEVERS ARE USED

Subject to technical modifications without notice

UNIVERSAL Pneumatic clamp with manual lever

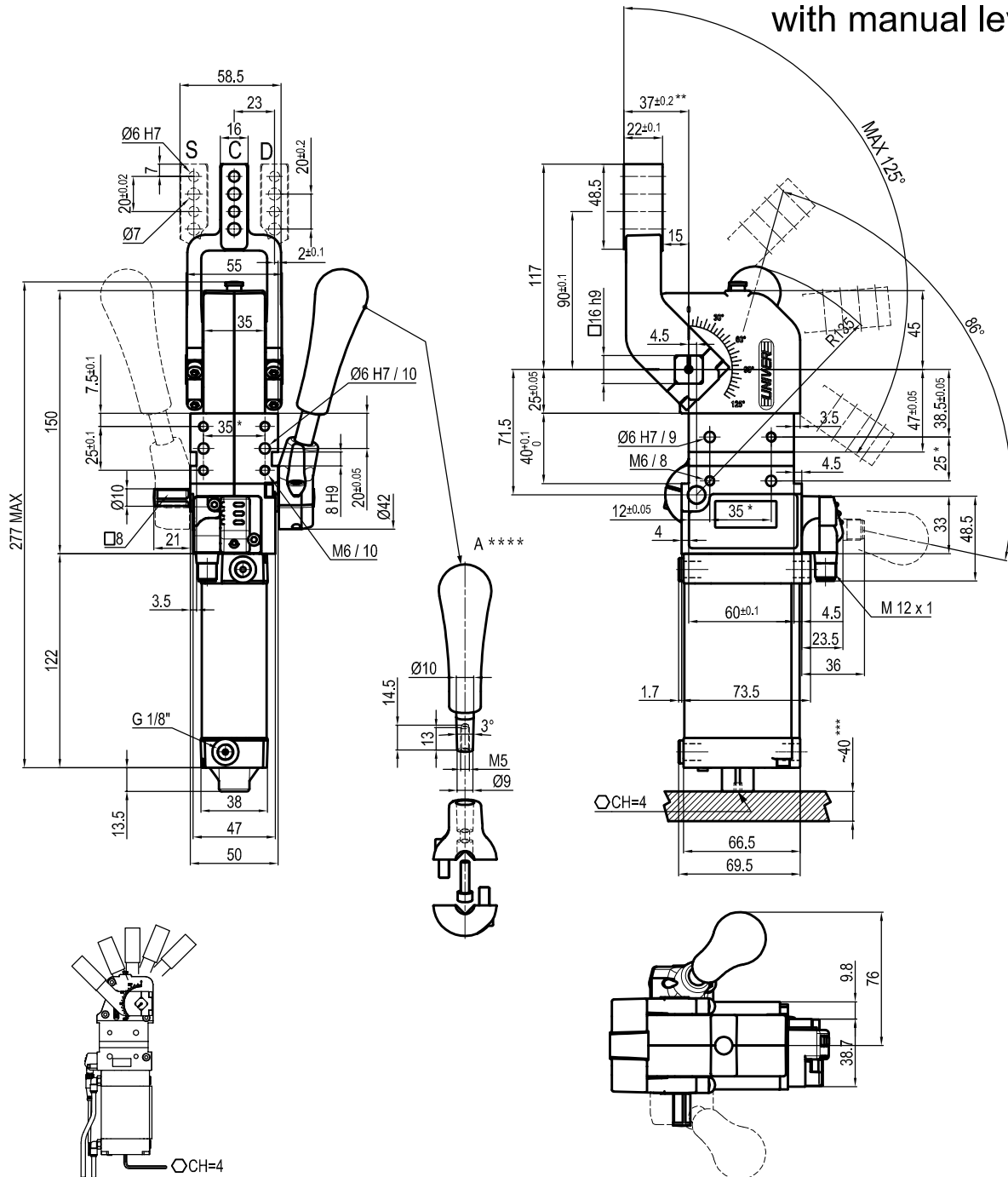

Bore Ø	Holding moment	Clamping moment	Weight (Clamping arm not included)
40 mm	600 Nm	170 Nm	1.8 Kg

Min./Max. operating pressure: **0,4 / 0,6 MPa**

Operating temperature: **5° + 45° C**

Opening angle: **adjustable from 0° to 125°**

With manual lever

Electronic sensor with M12 swivel connector that can be orientated at 0° or 90°

Supply voltage: 10±30 Vdc

IP code: **IP 65**

Pneumatic ports on both sides

* : TOLERANCE BETWEEN DOWELS ± 0.02, TO SCREW HOLES ± 0.1

** : TOLERANCE AT 80 mm FROM PIVOT POINT

*** : AREA TO ACCESS ANGLE ADJUSTMENT

**** : DIMENSIONS TO BE RESPECTED IN CASE OTHER MANUAL LEVERS ARE USED

Subject to technical modifications without notice

UNIVERSAL Pneumatic clamp arm at 45 mm from pivot point

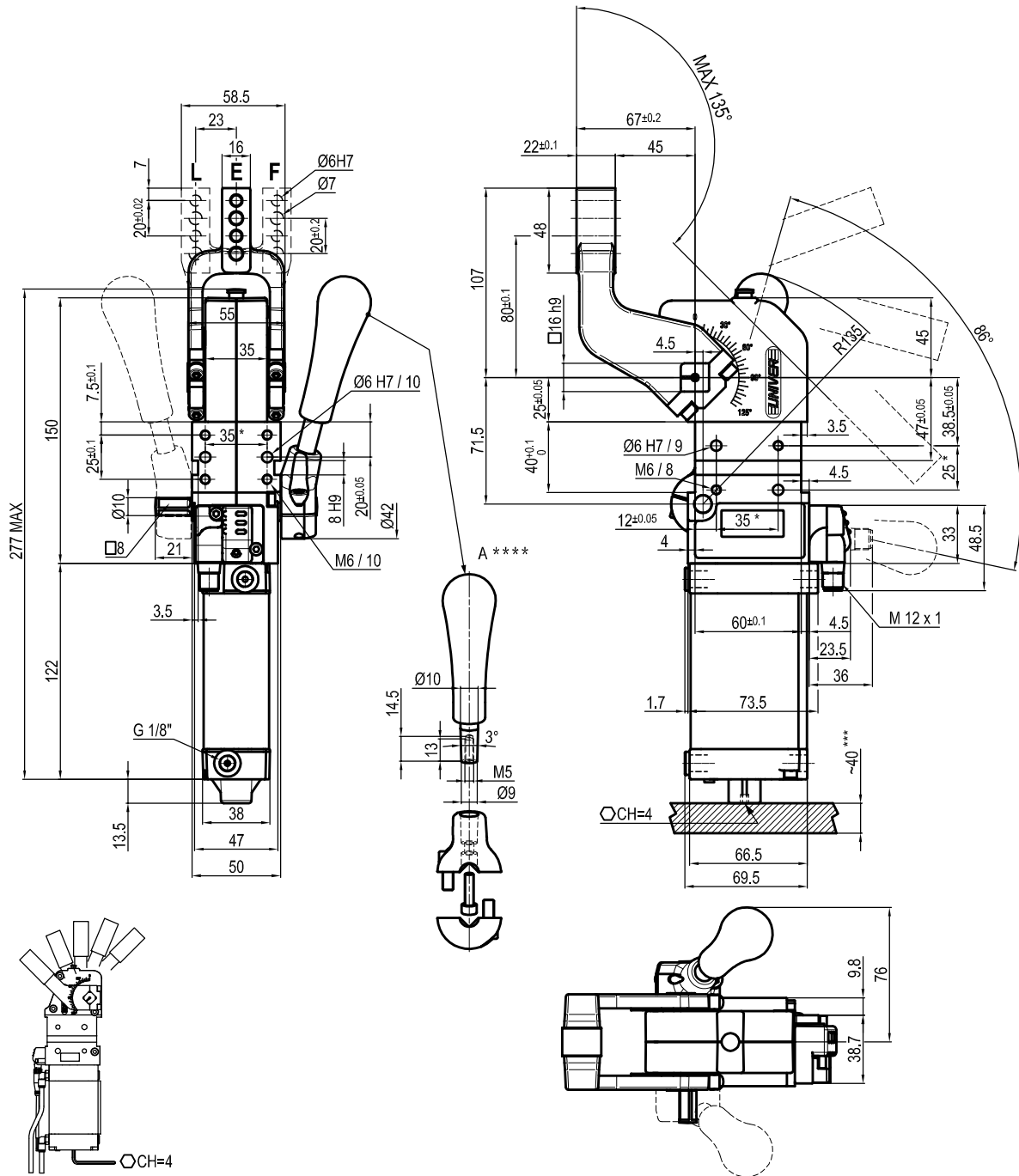

Bore Ø	Holding moment	Clamping moment	Weight (Clamping arm not included)
40 mm	600 Nm	170 Nm	1.8 Kg

Min./Max. operating pressure: **0,4 / 0,6 MPa**
 Operating temperature: **5° + 45° C**
 Opening angle: **adjustable from 0° to 135°**
 With manual lever
 Electronic sensor with M12 swivel connector that can be orientated at 0° or 90°
 Supply voltage: 10÷30 Vdc
 IP code: **IP 65**
 Pneumatic ports on both sides

* : TOLERANCE BETWEEN DOWELS ± 0.02, TO SCREW HOLES ± 0.1
 ** : TOLERANCE AT 80 mm FROM PIVOT POINT
 *** : AREA TO ACCES ANGLE ADJUSTMENT
 **** : DIMENSIONS TO BE RESPECTED IN CASE OTHER MANUAL LEVERS ARE USED

Subject to technical modifications without notice

UNIVERSAL Pneumatic clamp with manual lever

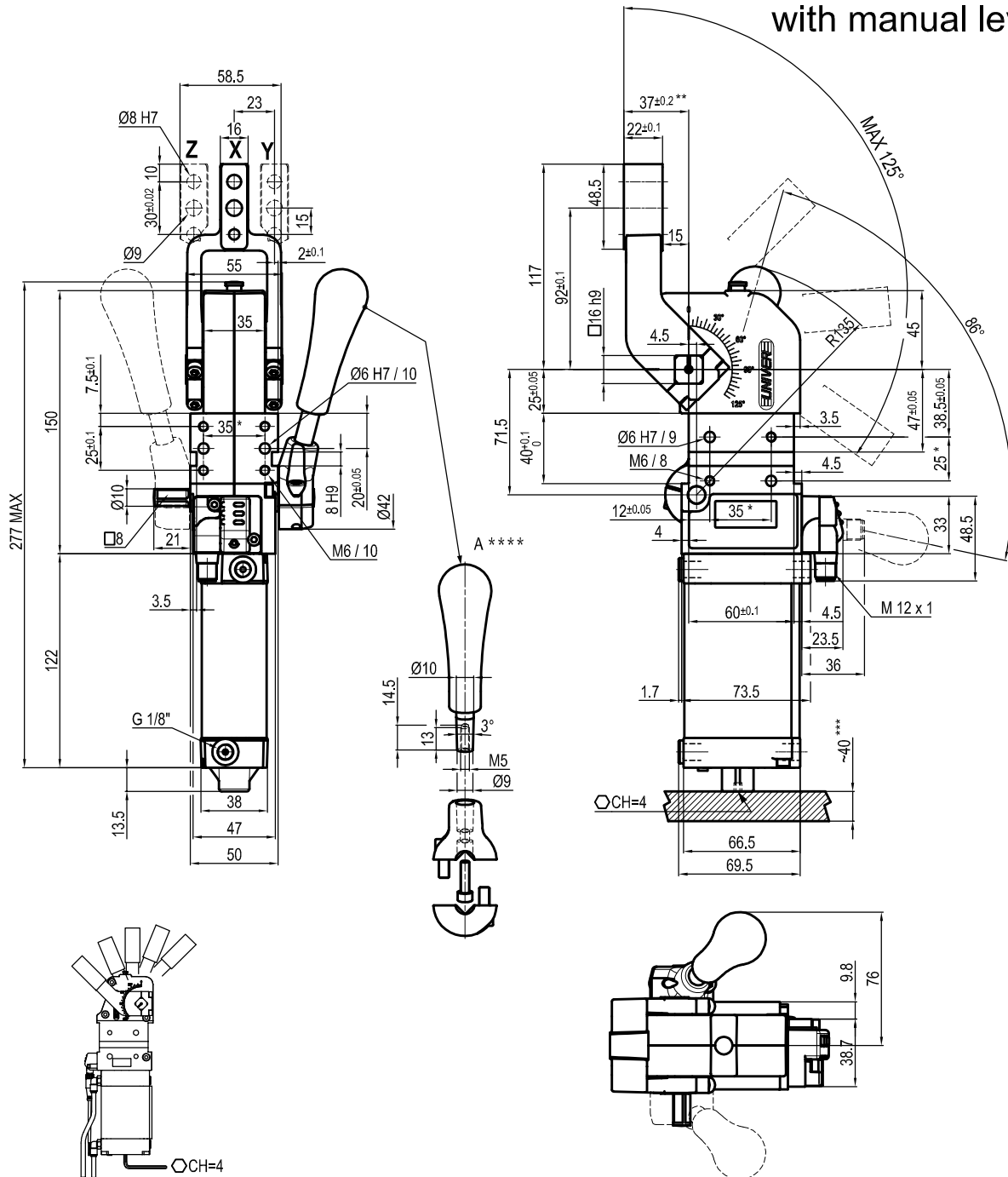

Bore Ø	Holding moment	Clamping moment	Weight (Clamping arm not included)
40 mm	600 Nm	170 Nm	1.8 Kg

Min./Max. operating pressure: **0,4 / 0,6 MPa**

Operating temperature: **5° + 45° C**

Opening angle: **adjustable from 0° to 125°**

With manual lever

Electronic sensor with M12 swivel connector that can be orientated at 0° or 90°

Supply voltage: 10±30 Vdc

IP code: **IP 65**

Pneumatic ports on both sides

* : TOLERANCE BETWEEN DOWELS ± 0.02, TO SCREW HOLES ± 0.1

** : TOLERANCE AT 80 mm FROM PIVOT POINT

*** : AREA TO ACCESS ANGLE ADJUSTMENT

**** : DIMENSIONS TO BE RESPECTED IN CASE OTHER MANUAL LEVERS ARE USED

Subject to technical modifications without notice

UNIVERSAL Pneumatic clamp with manual lever

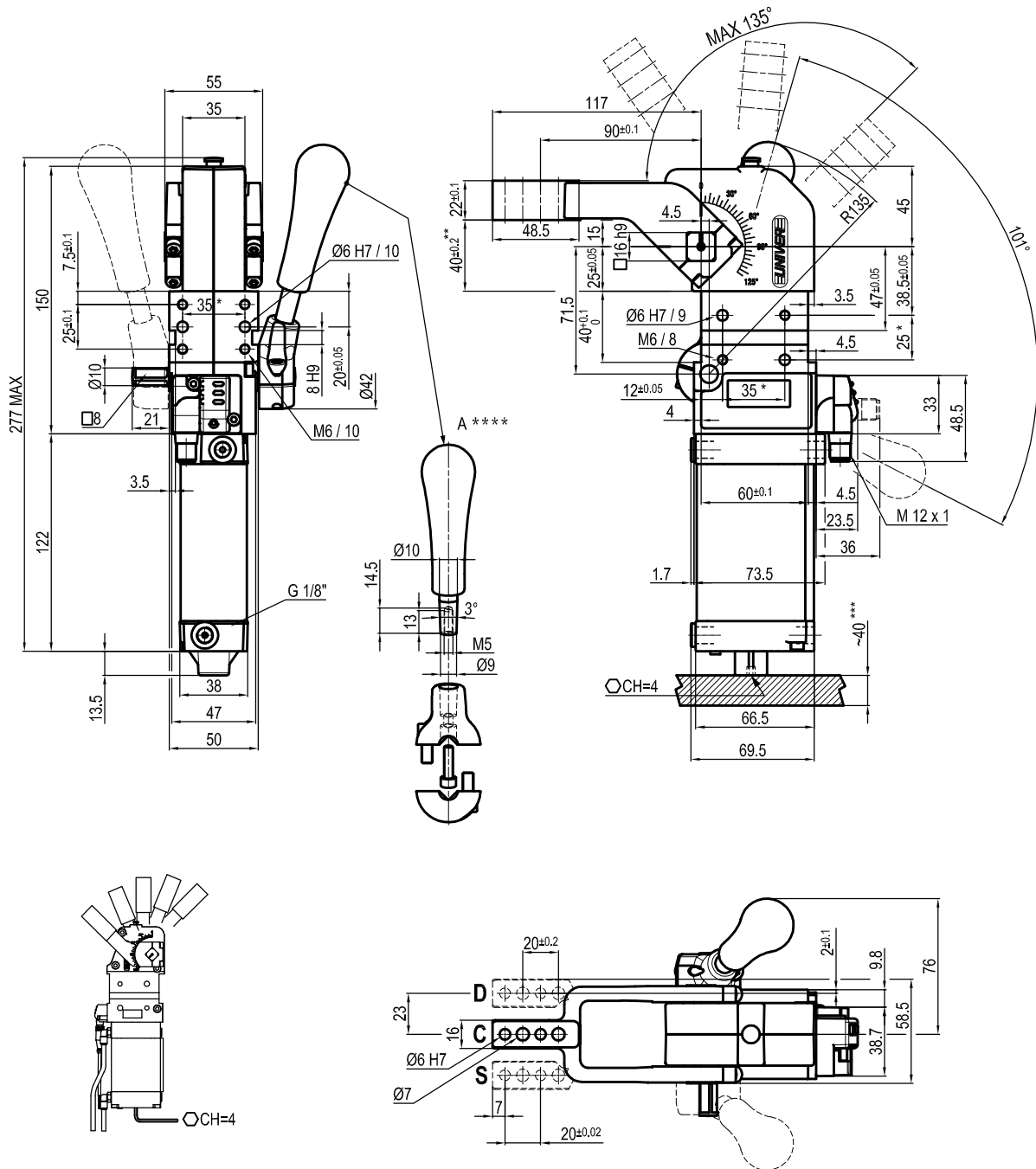

Bore Ø	Holding moment	Clamping moment	Weight (Clamping arm not included)
40 mm	600 Nm	170 Nm	1.8 Kg

Min./Max. operating pressure: **0,4 / 0,6 MPa**

Operating temperature: **5° + 45° C**

Opening angle: **adjustable from 0° to 135°**

With manual lever

Electronic sensor with M12 swivel connector that can be orientated at 0° or 90°

Supply voltage: 10÷30 Vdc

IP code: **IP 65**

Pneumatic ports on both sides

* : TOLERANCE BETWEEN DOWELS ± 0.02, TO SCREW HOLES ± 0.1

** : TOLERANCE AT 80 mm FROM PIVOT POINT

*** : AREA TO ACCESS ANGLE ADJUSTMENT

**** : DIMENSIONS TO BE RESPECTED IN CASE OTHER MANUAL LEVERS ARE USED

Subject to technical modifications without notice

UNIVERSAL Pneumatic clamp arm at 45 mm from pivot point

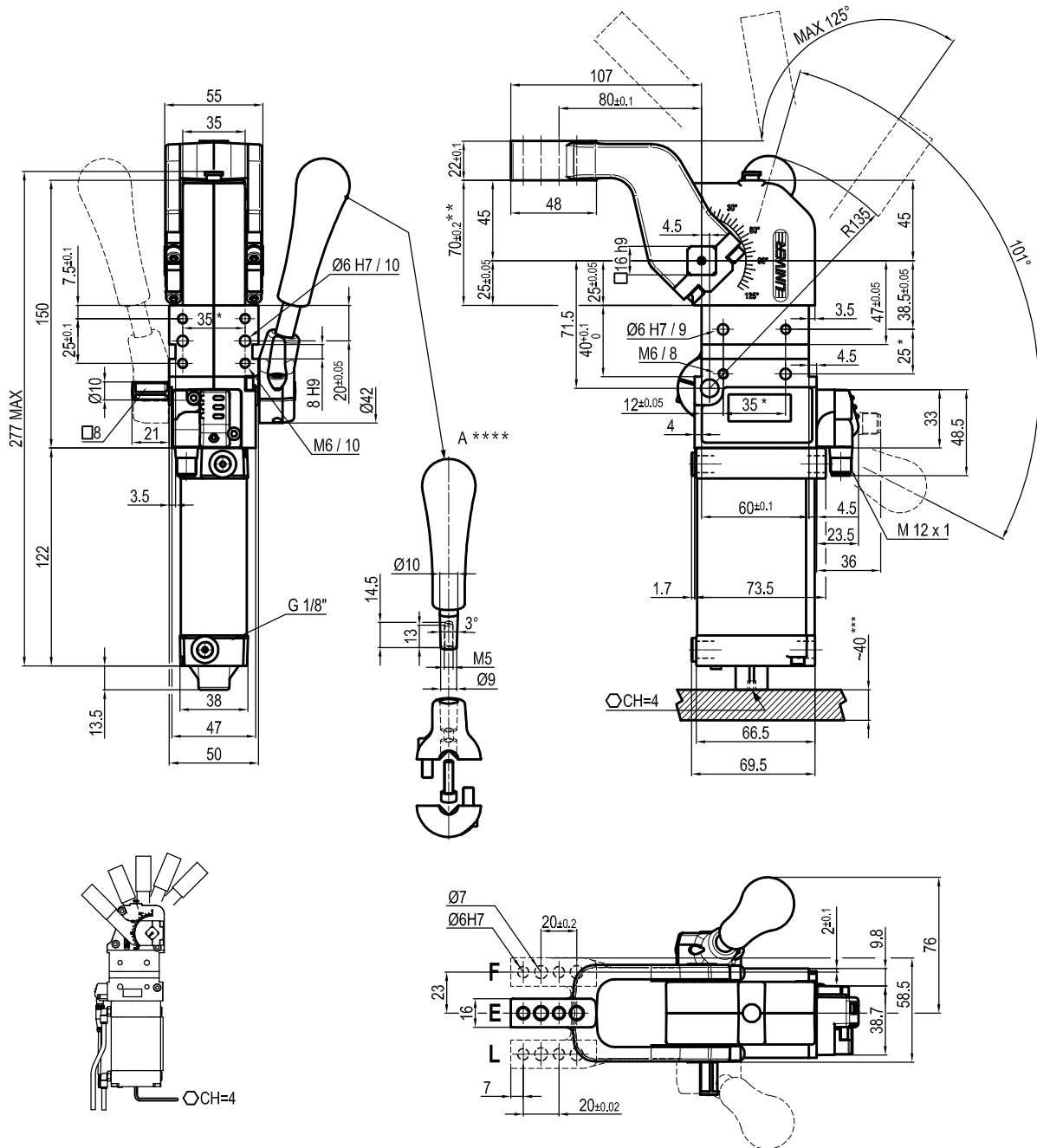

Bore Ø	Holding moment	Clamping moment	Weight (Clamping arm not included)
40 mm	600 Nm	170 Nm	1.8 Kg

Min./Max. operating pressure: **0,4 / 0,6 MPa**
 Operating temperature: **5° + 45° C**
 Opening angle: **adjustable from 0° to 125°**
 With manual lever
 Electronic sensor with M12 swivel connector that can be orientated at 0° or 90°
 Supply voltage: 10±30 Vdc
 IP code: **IP 65**
 Pneumatic ports on both sides

- * : TOLERANCE BETWEEN DOWELS ± 0.02, TO SCREW HOLES ± 0.1
- ** : TOLERANCE AT 80 mm FROM PIVOT POINT
- *** : AREA TO ACCESS ANGLE ADJUSTMENT
- **** : DIMENSIONS TO BE RESPECTED IN CASE OTHER MANUAL LEVERS ARE USED

Subject to technical modifications without notice

UNIVERSAL Pneumatic clamp with manual lever

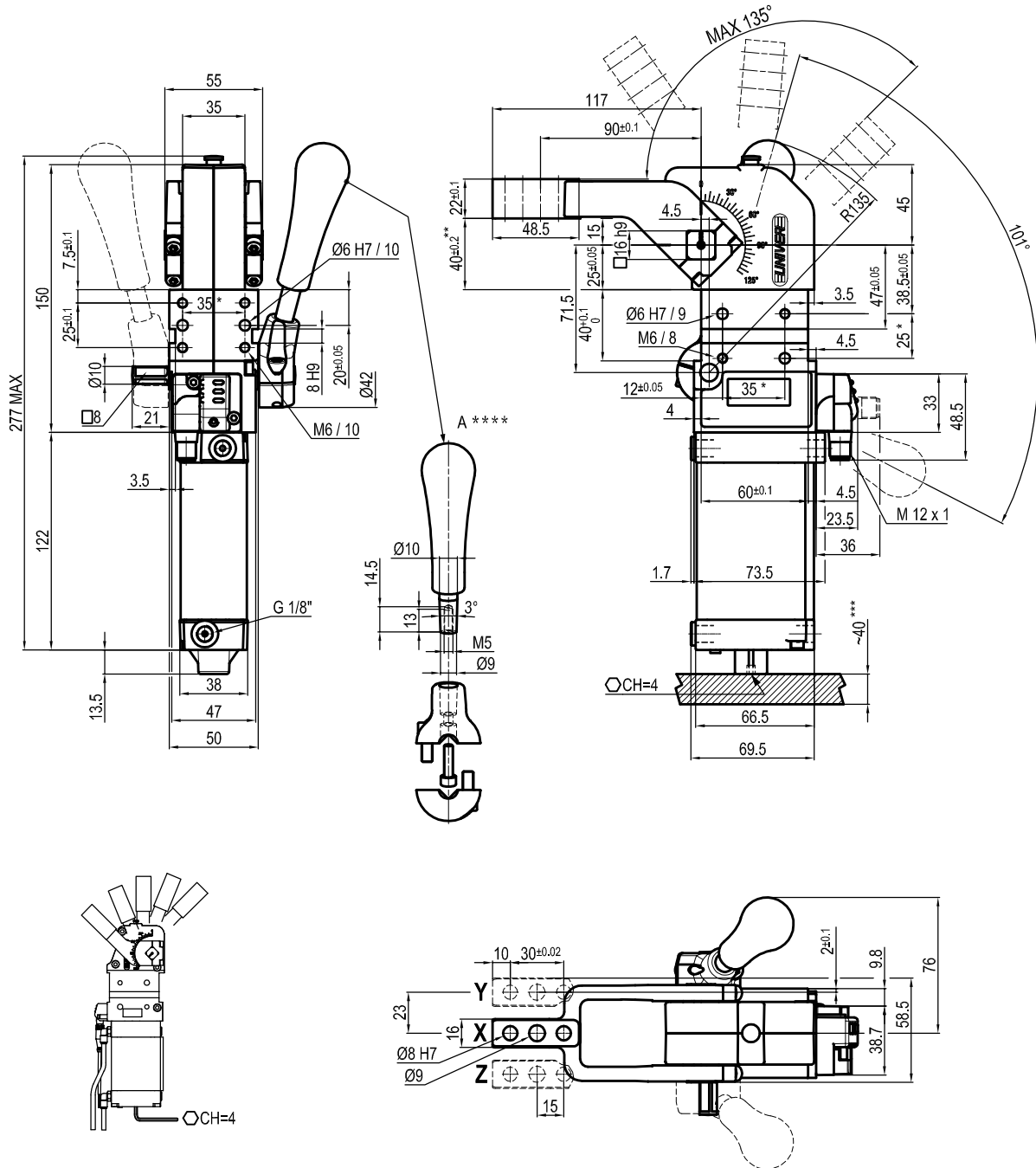

Bore Ø	Holding moment	Clamping moment	Weight (Clamping arm not included)
40 mm	600 Nm	170 Nm	1.8 Kg

Min./Max. operating pressure: **0,4 / 0,6 MPa**

Operating temperature: **5° + 45° C**

Opening angle: **adjustable from 0° to 135°**

With manual lever

Electronic sensor with M12 swivel connector that can be orientated at 0° or 90°

Supply voltage: 10÷30 Vdc

IP code: **IP 65**

Pneumatic ports on both sides

* : TOLERANCE BETWEEN DOWELS ± 0.02, TO SCREW HOLES ± 0.1

** : TOLERANCE AT 80 mm FROM PIVOT POINT

*** : AREA TO ACCESS ANGLE ADJUSTMENT

**** : DIMENSIONS TO BE RESPECTED IN CASE OTHER MANUAL LEVERS ARE USED

Subject to technical modifications without notice