

DSV2-4 - Shuttle Valve

Ball type

3 L/min (0.75 USgpm) • 240 bar (3500 psi)

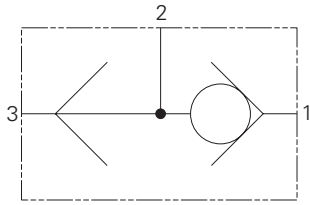

Operation

When a higher pressure is sensed at inlet 1 than at inlet 2 the ball within the cartridge is forced against a seat opening the higher pressure to outlet.

When the higher pressure appears at inlet 2 the ball is forced against the other seat which blocks inlet 1 and opens up inlet 2 to outlet.

Features

Cartridge design enabling speedy servicing when mounted in a body or in a composite manifold.

Sectional View

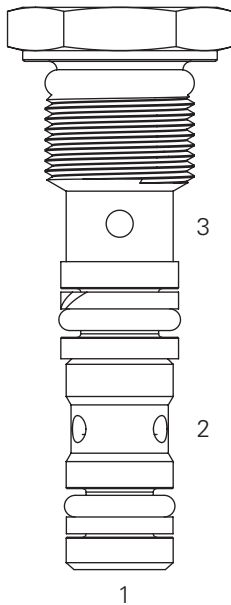

Performance Data

Ratings and Specifications

Performance data is typical with fluid at 21,8 cSt (105 SUS) and 49°C (120°F)

Typical application pressure (all ports)	240 bar (3500 psi) steel housing
Cartridge fatigue pressure (infinite life)	240 bar (3500 psi)
Rated flow	3 L/min (0.75 USgpm)
Internal leakage	Between ports 2 and 1, and 2 and 3 <5 drops/min maximum @ 240 bar (3500 psi)
Cavity	C-4-3
Temperature range	-40°C to +120°C (-40° to + 248°F)
Fluids	All general purpose hydraulic fluids such as MIL-H-5606, SAE 10, SAE 20, etc.
Filtration level	Cleanliness code 18/16/13
Weight cartridge only	0,02 kg (0.044 lbs)
Seal kits	9900176-000 (Buna-N) 9900177-000 (Viton®)

Viton is a registered trademark of E. I. DuPont

Description

This valve provides a means of sensing the higher pressures between two lines on a hydraulic circuit allowing this line to be used for an auxiliary function such as the removal of a mechanically applied brake, the operation of a gauge or to give a remote pressure sensing line for the control of a separate valve.

Note: This valve is intended for application as a load sense shuttle valve in load sensing systems

Where measurements are critical request certified drawings. We reserve the right to change specifications without notice.

DSV2-4 - Shuttle Valve

Ball type

3 L/min (0.75 USgpm) • 240 bar (3500 psi)

Model Code

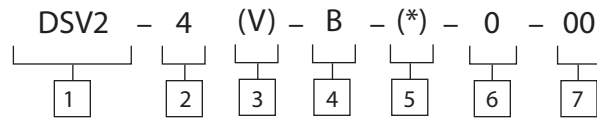

1 Function DSV2 - Shuttle Valve	3 Seals Blank - Buna-N V - Viton	5 Valve Housing Material Omit for cartridge only A - Aluminum S - Steel	7 Special Features 00 - None (Only required if valve has special features, omitted if "00")
2 Size 4 - 4 Size	4 Style B - Ball	6 Port Size O - Cartridge Only	

Dimensions

mm (inch)

Cartridge Only

Basic Code

DSV2-4

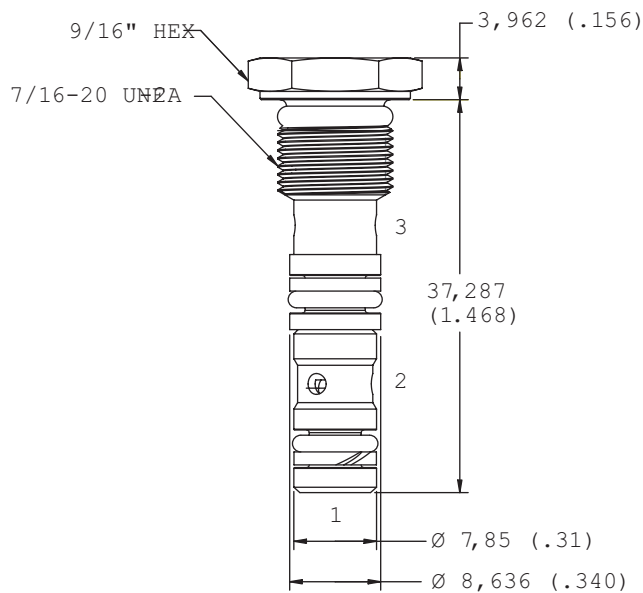

Note: Torque cartridge in aluminum or steel housing 8.1-13.6 Nm (6-10 ft lbs).



Aluminum housings can be used for pressures up to 210 bar (3000 psi). Steel housings must be used for operating pressures above 1210 bar (3000 psi).