

FDC1-20 - Flow Divider/Combiner

Line mounted, pressure compensated, spool type
Up to 141 L/min (37 USgpm) • 210 bar (3000 psi)

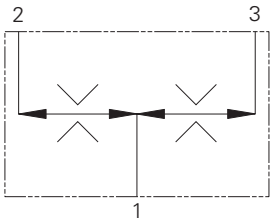

Operation

Inlet flow passes through the two matched orifices in the spools, through the spools and out of the radial holes in the sleeve. The matched orifices and the compensating springs ensure that the flow is divided equally, excess flow

in either direction causes the spool to move and close the radial holes in the sleeve until equilibrium is restored. In the reverse direction the spools close together and regulate the flow in through the radial ports.

Features

One valve synchronizes in both directions. Matched spools give high accuracy under load and pressure imbalance conditions.

Sectional View

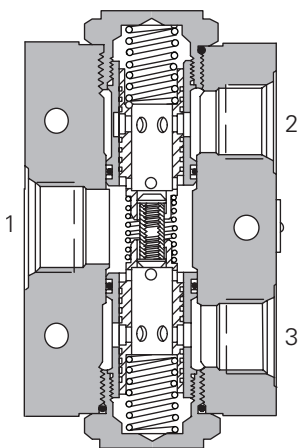

Performance Data

Ratings and Specifications

Performance data is typical with fluid at 21,8 cSt (105 SUS) and 49°C (120°F)

Typical application pressure (all ports)	210 bar (3000 psi)
Cartridge fatigue pressure (infinite life)	210 bar (3000 psi)
Rated inlet flow	See model code
Fluids	All general purpose hydraulic fluids such as MIL-H-5606, SAE 10, SAE 20, etc.
Filtration	Cleanliness code 18/16/13
Standard housing materials	Aluminum
Weight cartridge only	2,6 kg. (5.75 lbs)
Seal kits	889639 (Buna-N) 889643 (Viton [®])

Viton is a registered trademark of E.I. DuPont

Description

This range of flow divider/combiner valves gives division of input flow into two equal parts and re-combination of flow in the reverse direction. Pressure compensation ensures that whether dividing or combining, equal flow is maintained over a wide range of pressure variation. A typical use of these valves is to divide a pump flow to operate two actuators (which may be under different load conditions and at different pressures) and to re-combine the return flows to synchronize actuator movement. Flow variation is within $\pm 10\%$ with the maximum variation of pressure and inlet flow and under normal conditions will be significantly less.

Pressure Drop

Cartridge only

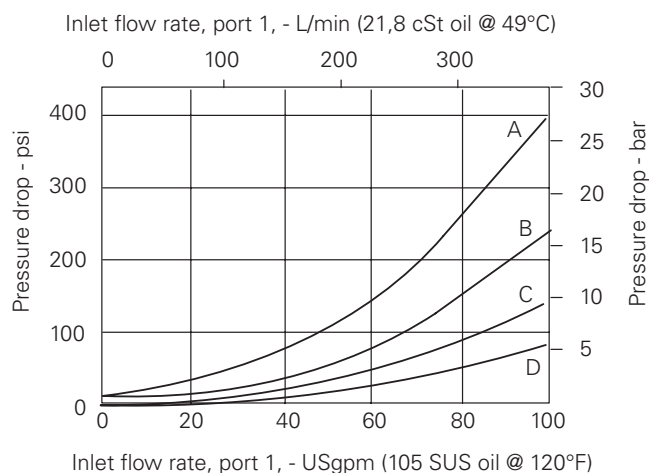

Flow Division

(See model code position 5)

A - 3* spool

B - 4* spool

C - 6* spool

D - 8* spool

Where measurements are critical request certified drawings. We reserve the right to change specifications without notice.

FDC1-20 - Flow Divider/Combiner

Line mounted, pressure compensated, spool type
Up to 141 L/min (37 USgpm) • 210 bar (3000 psi)

Model Code

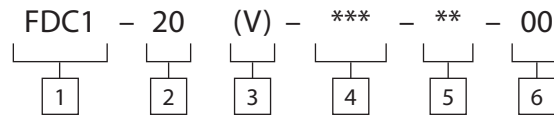

1 Function
FDC1 - Flow divider/combiner

2 Size
20 - 20 size

3 Seals
Blank - Buna-N
V - Viton®

4 Port Size
16T - SAE 16 (light duty)
20T - SAE 20 (light duty)
(Available as a complete assembly only.)

5 Flow Divisions (Ratios)

Code	Flow Division % Max		Inlet Flow	
	Port 3	Port 2	L/min	(USgpm)
33	50	50	114,0	(30)
34	43	57	83,6	(22)
36	33	67	57,0	(15)
44	50	50	140,6	(37)
66	50	50	140,6	(37)
88	50	50	114,0	(30)

6 Special Features

00 - None
(Only required if valve has special features, omitted if "00")

Dimensions

mm (inch)

Complete Valve
Basic Code
FDC1-20

Torque cartridge in housing to
128-155 Nm (95-115 ft lbs)

Notes: Minimum inlet flow
should not be less than 1/4
of maximum inlet flow for a
given code.

