

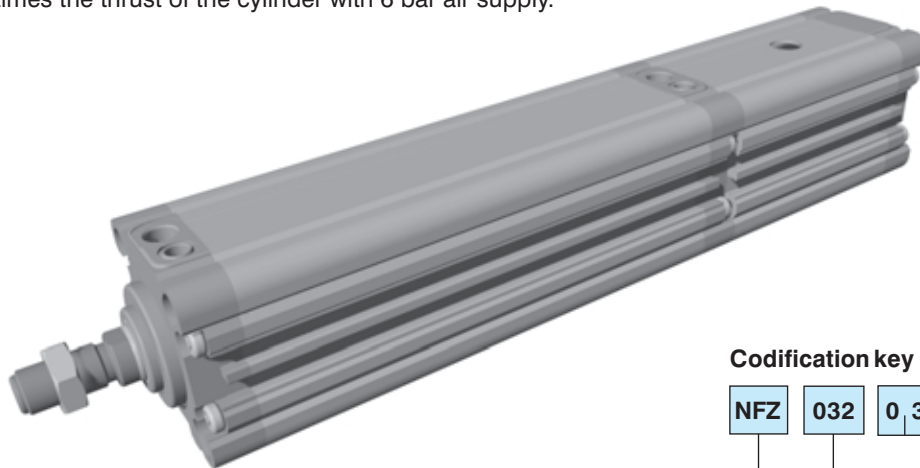

TECHNICAL CHARACTERISTICS

- Locking system axially placed to the cylinder and integrated in its interior in the rear part.
- High repeatability and intervention speed (16 m/s).
- Recommended use: emergency braking intervention at allowed cylinder speed; for repeated functioning, as locking unit or emergency braking ≤ 50 mm/s.
- Holding force of the rod, without axial backlash ≥ 3 times the thrust of the cylinder with 6 bar air supply.
- The locking force does not depend on ambient conditions or maintenance of the rod.



Codification key

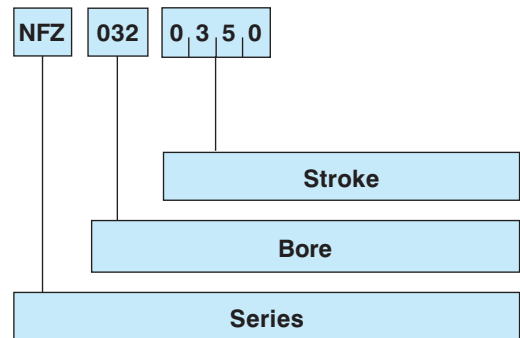

Working pressure: 3 ÷ 10 bar
 Ambient temperature: -10°C ÷ 70°C
 Fluid: filtered air 30 µm
 Barrel profile of extruded aluminium alloy with groove for flush-mounted sensors (section accessories page 2-V)
 Piston rod in chromium-plated steel
 The locking unit blocks if there is no signal and/or air supply
 Minimum pressure: ≥ 3 bar
 Mounting elements: (section cylinders page 49-I)

SERIES
 Pneumatic actuator with integrated safety locking system

BORE
 032-040-050-063 mm

STROKE MAX
 350 mm for $\varnothing 32$
 450 mm for $\varnothing 40$
 600 mm per $\varnothing 50$
 750 mm for $\varnothing 63$

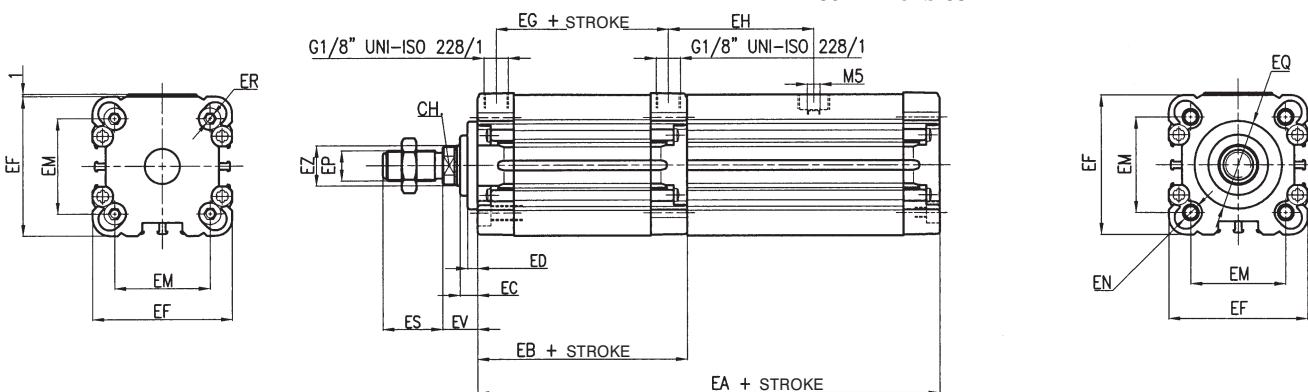

Ø	EA	EB	EC	ED	EF	EG	EH	EM	EN	EP	EQ	ER	ES	EV	EZ	CH
32	177	84	7	4	46	68,5	55,5	32,5	M6 x 13	M10 x 1,25	ø 30	M4 x 10	22	14	12	10
40	185	89	7	4	56	74	58	38	M6 x 13	M12 x 1,25	ø 35	M6 x 10	24	14	16	13
50	194	94	10	5	66	76	63	46,5	M8 x 17,5	M16 x 1,25	ø 40	M6 x 10	32	18	20	17
63	214	114	10	5	79	99	63	56,5	M8 x 18	M16 x 1,25	ø 45	M6 x 10	32	18	20	17